

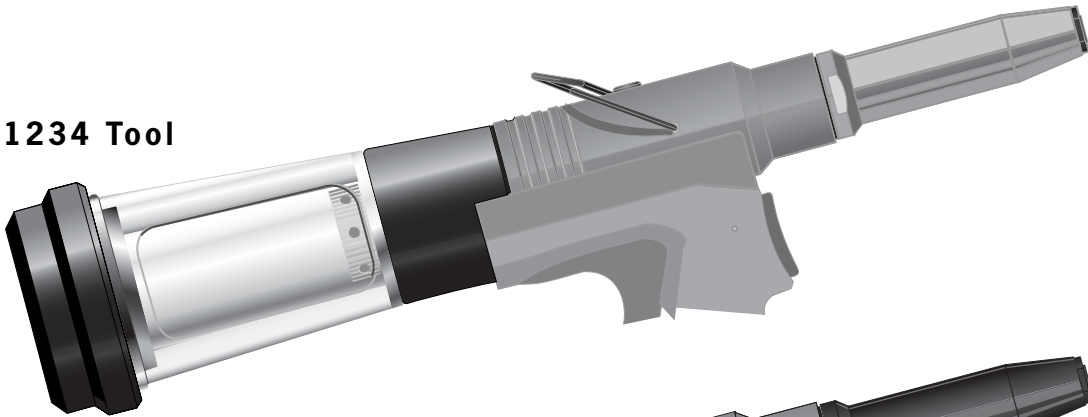

Instruction Manual

Original Instruction

71234 Tool



71233 Tool



Genesis® G4

Hydro-Pneumatic Power Tool

71233 Removable Bottle and 71234 Fixed Bottle

Contents

Safety Instructions	4	Servicing the Tool	
Specifications		Daily / Weekly	16
Tool Specification	5	MolyLithium Grease EP 3753 Safety Data	16
71233 and 71234 Tool Dimensions	5	Molykote® 55m Grease Safety Data	17
Intent of Use		Molykote® 111 Grease Safety Data	17
Range of Fasteners	6	Service Kit	18
Part Numbering	6	Maintenance	18
Putting into Service		Nose Equipment	18
Air Supply	7	Dismantling the Tool	19
71233 Tool Removable Bottle	7	Head Assembly	19
71234 Tool Fixed Bottle	7	Pneumatic Piston Assembly	20
Adjusting the Vacuum Extraction	7	Air Valve	20
Operating Procedure	8	Rotary Valve	21
Avtainer® and Maxlok®	8	Trigger	21
Removable Stem Collector Bottle 71233-05100	8	Common Parts	
Nose Assemblies		General Assembly of Common Parts 71233-02000 and 71234-02000	22
Nose Tip Selection	9	Parts List for Common Parts 71233-02000 and 71234-02000	23
Fitting Instructions - All Nose Assemblies except Avtainer® and Maxlok®	9	Stem Collector Bottles Removable and Fixed	
Servicing Instructions	9	71233 Tool Removable	24
Nose Tips	10 - 12	71234 Tool Fixed	24
Type 1	10	Priming	
Type 2, Type 5 and Type 6	11	Oil Details	25
Type 7 and Maxlok®	12	Hyspin® VG32 Oil Safety Data	25
Fitting Instructions for Avtainer® and Maxlok®	13	Priming Kit	26
Nose Assemblies		Priming Procedure	27
Servicing Instructions for all Nose Assemblies	13	Fault Diagnosis	
Accessories		Symptom, Possible Cause and Remedy	28
Stem Deflector	14		
Preparing the Base Tool for use with Stem Deflector Extension	14		

LIMITED WARRANTY

Avdel makes the limited warranty that its products will be free of defects in workmanship and materials which occur under normal operating conditions. This Limited Warranty is contingent upon: (1) the product being installed, maintained and operated in accordance with product literature and instructions, and (2) confirmation by Avdel of such defect, upon inspection and testing. Avdel makes the foregoing limited warranty for a period of twelve (12) months following Avdel's delivery of the product to the direct purchaser from Avdel. In the event of any breach of the foregoing warranty, the sole remedy shall be to return the defective Goods for replacement or refund for the purchase price at Avdel's option. THE FOREGOING EXPRESS LIMITED WARRANTY AND REMEDY ARE EXCLUSIVE AND ARE IN LIEU OF ALL OTHER WARRANTIES AND REMEDIES. ANY IMPLIED WARRANTY AS TO QUALITY, FITNESS FOR PURPOSE, OR MERCHANTABILITY ARE HEREBY SPECIFICALLY DISCLAIMED AND EXCLUDED BY AVDEL.

Avdel UK Limited policy is one of continuous product development and improvement and we reserve the right to change the specification of any product without prior notice.

Safety Instructions

This instruction manual must be read with particular attention to the following safety rules, by any person installing, operating, or servicing this tool.

- 1** Do not use outside the design intent.
- 2** Do not use equipment with this tool/machine other than that recommended and supplied by Avdel UK Limited.
- 3** Any modification undertaken by the customer to the tool/machine, nose assemblies, accessories or any equipment supplied by Avdel UK Limited or their representatives, shall be the customer's entire responsibility. Avdel UK Limited will be pleased to advise upon any proposed modification.
- 4** The tool/machine must be maintained in a safe working condition at all times and examined at regular intervals for damage and function by trained competent personnel. Any dismantling procedure shall be undertaken only by personnel trained in Avdel UK Limited procedures. Do not dismantle this tool/machine without prior reference to the maintenance instructions. Please contact Avdel UK Limited with your training requirements.
- 5** The tool/machine shall at all times be operated in accordance with relevant Health and Safety legislation. In the U.K. the "Health and Safety at Work etc. Act 1974" applies. Any question regarding the correct operation of the tool/machine and operator safety should be directed to Avdel UK Limited.
- 6** The precautions to be observed when using this tool/machine must be explained by the customer to all operators.
- 7** Always disconnect the air line from the tool/machine inlet before attempting to adjust, fit or remove a nose assembly.
- 8** Do not operate a tool/machine that is directed towards any person(s) or the operator.
- 9** Always adopt a firm footing or a stable position before operating the tool/machine.
- 10** Ensure that vent holes do not become blocked or covered.
- 11** The operating pressure shall not exceed 7 bar.
- 12** Do not operate the tool if it is not fitted with a complete nose assembly or swivel head unless specifically instructed otherwise.
- 13** Care shall be taken to ensure that spent stems are not allowed to create a hazard.
- 14** If the tool is fitted with a stem collector, it must be emptied when half full.
- 15** The Tool MUST NOT be operated with the Stem Collector Bottle removed.
- 16** If the tool is fitted with a stem deflector, it should be rotated until the aperture is facing away from the operator and other person(s) working in the vicinity.
- 17** When using the tool, the wearing of safety glasses is required both by the operator and others in the vicinity to protect against fastener ejection, should a fastener be placed 'in air'. We recommend wearing gloves if there are sharp edges or corners on the application.
- 18** Take care to avoid entanglement of loose clothes, ties, long hair, cleaning rags etc. in the moving parts of the tool which should be kept dry and clean for best possible grip.
- 19** When carrying the tool from place to place keep hands away from the trigger/lever to avoid inadvertent start up.
- 20** Excessive contact with hydraulic fluid oil should be avoided. To minimize the possibility of rashes, care should be taken to wash thoroughly.
- 21** C.O.S.H.H. data for all hydraulic oils and lubricants is available on request from your tool supplier.

Specifications

Tool Specification

Air Pressure	Minimum - Maximum	5-7 bar
Free Air Volume Required	@ 5.5 bar	4.3 litres
Stroke	Minimum	17 mm
Pull Force	@ 5.5 bar	18.68 kN
Cycle Time	Approximately	1.2 seconds
Noise Level		75 dB(A)
Weight	Including nose equipment	2.25 kg
Vibration	Less than	2.5 m/s ²

71233 and 71234 Tool Dimensions

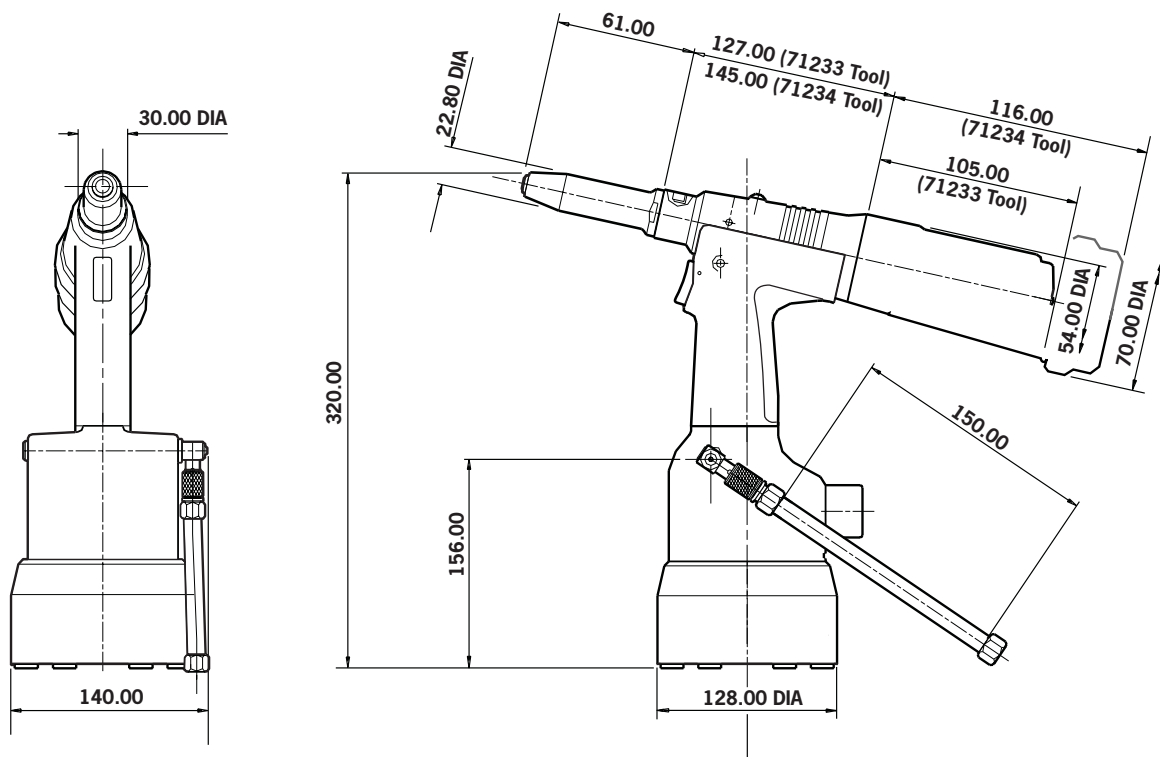

Dimensions in millimetres

Intent of Use

Range of Fasteners

nG4 is a hydro-pneumatic tool designed to place Avdel® breakstem fasteners at high speed making it ideal for batch or flow-line assembly in a wide variety of applications throughout all industries. It can place all fasteners listed opposite.

The tool features a vacuum system for fastener retention and trouble free collection of the spent stems regardless of tool orientation.

NOSE EQUIPMENT MUST BE FITTED AS DESCRIBED ON PAGE 9.

FASTENER NAME	FASTENER SIZE ($\frac{MM}{IN}$)													
	4.3	4.8	5	5.2	6	6.4	6.5	7	8	9	9.5	10	11	12
	-	$\frac{3}{16}$	-	-	-	$\frac{1}{4}$	-	-	-	-	$\frac{3}{8}$	-	-	-
AVEX®		●				●								
STAVEX®		●				●								
AVINOX®II		●				●								
AVIBULB®		●			●	●								
BULBEX®		●												
T-LOK®	●	●												
AVDEL® SR		●				●								
HEMLOK®						●								
MAXLOK®		●				●								
AVTAINER®											●			
* AVSEAL® II								●	●	●		●	●	●
Q RIVET		●				●								
T RIVET		●				●								
AVDELMATE®		●				●								
KLAMP-TITE®		●				●								
KLAMP TITE KTR®		●				●								
* LOCKBOLT		●				●								

* For $\frac{3}{16}$ " and $\frac{1}{4}$ " Lockbolt equipment refer to separate Data Sheet 07900-00795.

** For Avseal® equipment refer to separate Data Sheet 07900-00840.

Part Numbering

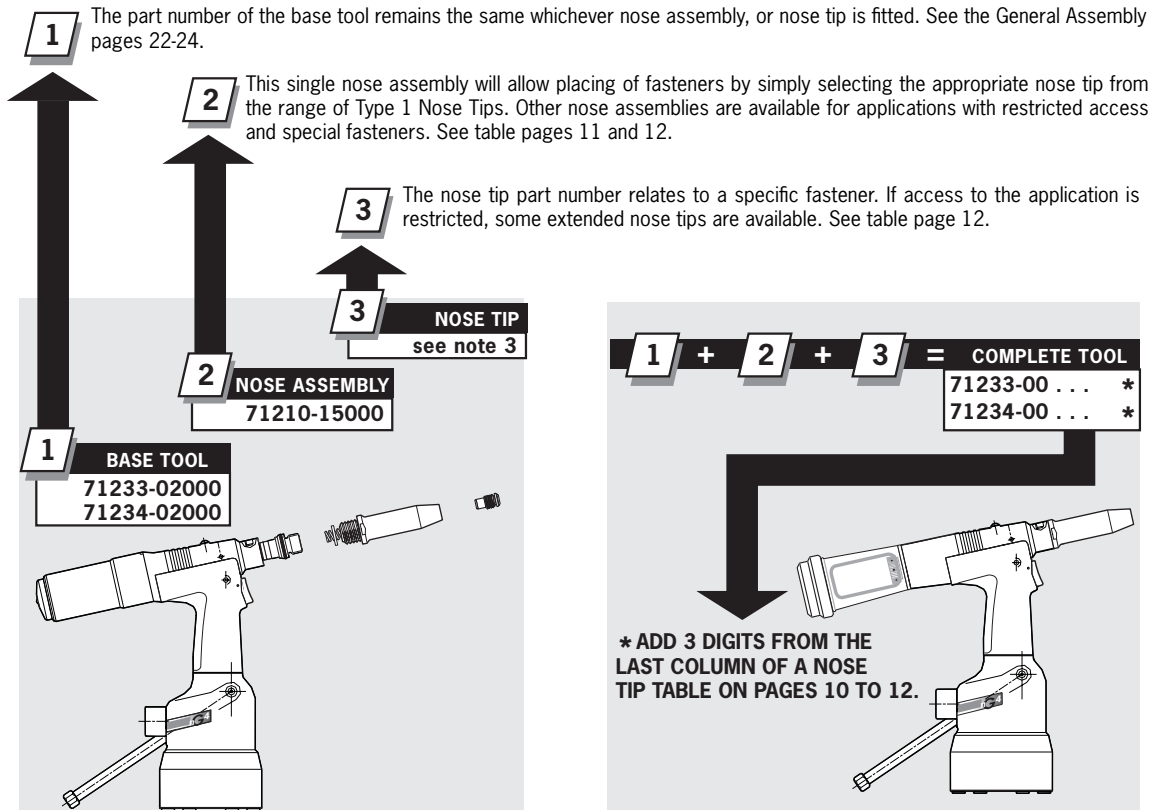

Putting into Service

Air Supply

All tools are operated with compressed air at an optimum pressure of 5.5 bar. We recommend the use of pressure regulators and filtering systems on the main air supply. These should be fitted within 3 metres of the tool (see diagram below) to ensure maximum tool life and minimum tool maintenance.

Air supply hoses should have a minimum effective working pressure rating of 150% of the maximum pressure produced in the system or 10 bar, whichever is the highest. Air hoses should be oil resistant, have an abrasion resistant exterior and should be armoured where operating conditions may result in hoses being damaged. All air hoses MUST have a minimum bore diameter of 6.4 millimetres or 1/4 inch.

71233 Tool Removable Bottle

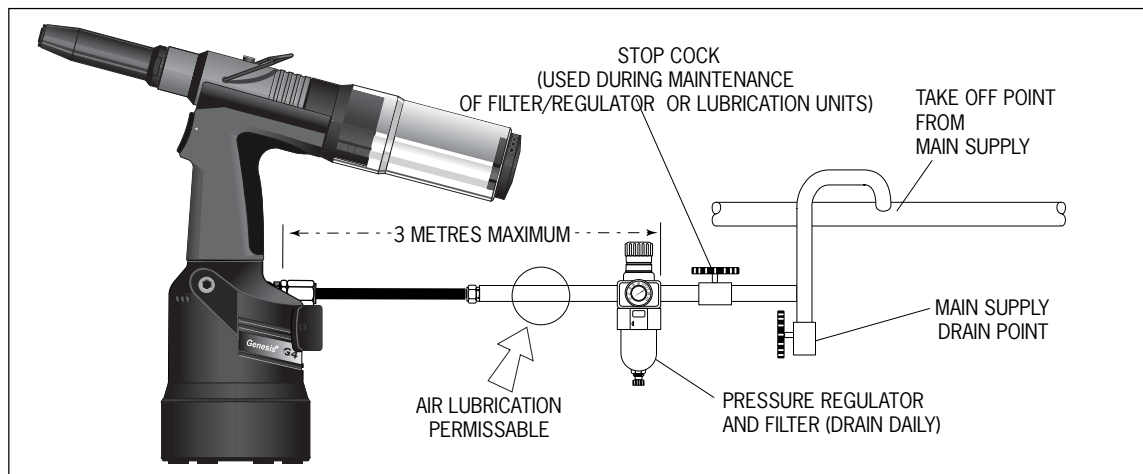

71234 Tool Fixed Bottle

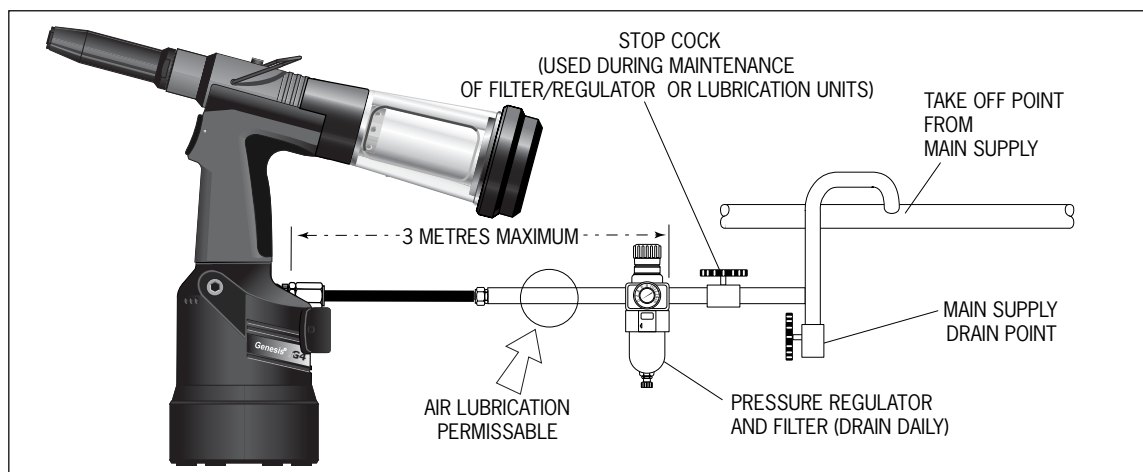

Adjusting the Vacuum Extraction

- Using a screwdriver, turn rotary valve **38** until the air flow at the rear of the tool ceases.
- With the nose of the tool pointing downwards, insert a fastener into the nose and hold it into position.
- Turn the rotary valve either way until there is sufficient suction to retain the fastener.

Putting into Service

Operating Procedure

- Ensure that the correct nose assembly suitable for the fastener is fitted.
- Connect the tool to the air supply.
- Insert the fastener stem into the nose of the tool. If using a standard nose assembly, the fastener should remain held in by the vacuum system.
- Bring the tool with the fastener to the application so that the protruding fastener enters squarely into the hole of the application.
- Fully actuate the trigger. The tool cycle will broach the fastener and with standard nose assemblies the broken stem will be projected to the rear of the tool into the collector bottle.

Avtainer® and Maxlok®

- Ensure that the correct nose assembly is fitted, see pages 12 and 13.
- Connect the tool to the air supply.
- Push the Avtainer® or Maxlok® stem through the application hole.
- Place the collar on the stem (orientation as shown below).
- Keeping the head of the stem against the application, push the tool onto the protruding stem.
- Fully depress the trigger. One cycle will ensure that the collar is swaged into the lock grooves of the stem and that the stem breaks at the breaker groove.
- Release the trigger. The tool completes its cycle by pushing itself off the collar and the spent stem will be pushed to the rear of the tool on insertion of the next fastener.

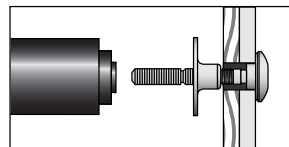

Placing AVTAINER®

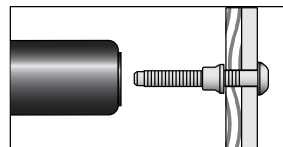

Placing MAXLOK®

Removable Stem Collector Bottle 71233-05100

- A quarter turn rotation removes or replaces the collector bottle.

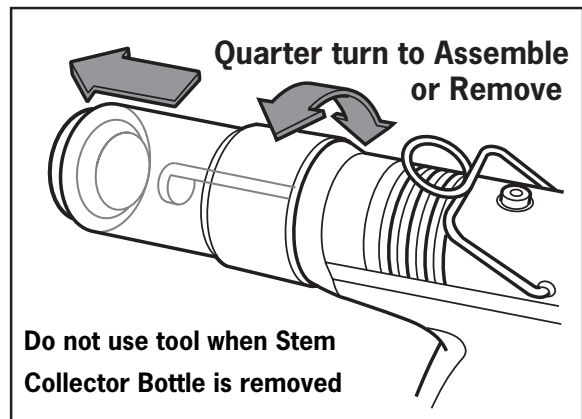

Nose Assemblies

Nose Tip Selection

IMPORTANT

Nose assemblies do NOT include nose tips. Nose tips must be ordered separately.

A tool must always be fitted with the correct nose assembly and nose tip for your fastener and must be ordered separately, refer to the 'NOSE TIPS' tables on pages 10 to 13.

If your application presents no access restriction use a Type 1 nose tip. If you are placing Avtainer® a Type 5, Hemlok® and 1/4" Interlock® a Type 6 must be used. Maxlok® requires a special nose assembly which does not make use of any nose tip, see pages 10 to 13.

Dimensions 'A' and 'B' will help you assess the suitability of a particular nose tip.

You should also check that the dimensions of the nose casing will not restrict access to your application. If access is restricted Type 2 nose tips with extra reach, are available for some fasteners. Refer to the table on page 12.

It is essential that a fastener-compatible nose assembly and nose tip are fitted prior to operating the tool (no nose tip with Maxlok®).

Fitting Instructions - All Nose Assemblies except Avtainer® and Maxlok®

IMPORTANT

The air supply must be disconnected when fitting or removing nose assemblies.

Item numbers in **bold** refer to nose assembly components in all nose tip tables.

- Lightly coat Jaws **4** with Moly Lithium grease*.
- Drop Jaws **4** into Jaw Housing **3** or Chuck Collet **9** depending on which nose assembly you are using.
- Insert Jaw Spreader **5** into Jaw Housing **3** or insert Front Spring Guide **10** into Chuck Collet **9**.
- Locate Buffer **6** on Jaw Spreader **5**.
- Locate Spring **7** onto Jaw Spreader **5** or onto Front Spring Guide **10**.
- Screw Rear Spring Guide **11** into Chuck Collet **9**.
- Fit Locking Ring **8** onto the Jaw Spreader Housing of the tool.
- Holding tool pointing down, screw the assembled Jaw Housing **3** or Chuck Collet **9** onto the Jaw Spreader Housing and tighten with spanner*.
- Screw the nose tip into Nose Casing **1** and tighten with spanner*.
- Place Nose Casing **1** over Jaw Housing **3** or Chuck Collet **9** and screw onto the tool, tightening with spanner*.

Servicing Instructions

Nose assemblies should be serviced at weekly intervals. You should hold some stock of all internal components of the nose assembly and nose tips as they will need regular replacement.

Use Spanner 07900-00849 (supplied with tool) to assist when servicing nose equipment.

- Remove the nose equipment using the reverse procedure to the 'Fitting instructions'.
- Any worn or damaged part should be replaced.
- Clean and check wear on Jaws.
- Ensure that neither the Jaw Spreader nor the Front Spring Guide is distorted.
- Check Spring **7** is not distorted.
- Assemble according to fitting instructions above.

* Item included in the nG4 Service Kit. For complete list see page 18.

Nose Assemblies

Nose Tips

TYPE 1 NOSE TIPS

¹ In inches then in millimetres.

² Head forming nose tips for use with countersunk heads ONLY.

⁴ Material of the body then of the stem. 'Al' is the abbreviation for Aluminium.

⁵ Domehead.

⁶ Countersunk.

NOSE ASSEMBLY part n° 71210-15000

ITEM	DESCRIPTION	PART N°
1	NOSE CASING	07340-00306
2	'O' RING	07003-00067
3	JAW HOUSING	07340-00304
4	JAWS	71210-15001
5	JAW SPREADER	07498-04502
6	BUFFER	71210-05001
7	SPRING	07500-00418
8	LOCKING RING	07340-00327

NAME	FASTENER		MATERIAL	NOSE TIP (mm)			see below
	Ø ¹			PART N°	'A'	'B'	
AVEX® Large flange	3/16	4.8	Aluminium	07381-04701	12.7	2.8	... 010
	3/16	4.8	Aluminium	07340-04800	19.0	3.3	... 016
	3/16	4.8	Steel	07490-04401	12.7	3.3	... 017
	3/16	4.8	Aluminium	07340-06601 ²	12.7	4.1	... 015
	1/4	6.4	Aluminium	07612-02001	12.7	3.3	... 021
STAVEX® Countersunk	3/16	4.8	Steel	07381-04701	12.7	2.8	... 010
	3/16	4.8	Steel	07381-04701	12.7	2.8	... 010
	3/16	4.8	Stainless Steel	07381-04701	12.7	2.8	... 010
	3/16	4.8	Steel	07340-04800	19.0	3.3	... 016
BULBEX®	3/16	4.8	Aluminium	07381-04701	12.7	2.8	... 010
AVINOX® II	3/16	4.8	Stainless Steel	07498-01401	12.7	4.8	... 082
T-LOK®	-	4.3	Steel	07340-06201	12.7	3.3	... 120
	3/16	4.8	Steel	07340-06201	12.7	3.3	... 120
AVIBULB®	3/16	4.8	Steel	07498-01401	12.7	4.8	... 082
	-	6.0	Steel	07612-02001	12.7	3.3	... 021
AVDEL® SR Countersunk	3/16	4.8	Any	07348-07001 ⁵	12.7	5.7	... 062
	1/4	6.4	Any	71220-60001	12.7	3.3	... 063
	3/16	4.8	Any	71210-16050 ⁶	12.7	5.7	... 064
Q RIVET	3/16	4.8	Any	07340-06201	12.7	3.3	... 120
	1/4	6.4	Any	07612-02001	12.7	3.3	... 021
AVDELMATE®	3/16	4.8	Any	07340-06201	12.7	3.3	... 120
	1/4	6.4	Any	07612-02001	12.7	3.3	... 021
T RIVET Large flange	3/16	4.8	Al/Al ⁴	703-A-25-6TA	15.9	9.5	... 380
	3/16	4.8	Al/Al ⁴	703-B-21	12.7	8.0	... 381
	3/16	4.8	Al/Steel ⁴	703-A-25-6T	15.9	9.5	... 383
Large flange	3/16	4.8	Al/Steel ⁴	703-B-26	12.7	9.0	... 384
	1/4	6.4	Al/Al ⁴	743-A-25-8TA	17.5	11.2	... 385
Large flange	1/4	6.4	Al/Al ⁴	743-B-21	12.7	8.0	... 386
	1/4	6.4	Al/Steel ⁴	743-A-25-8T	16.7	10.2	... 387
Large flange	1/4	6.4	Al/Steel ⁴	743-B-26	12.7	8.3	... 388
KLAMPTITE KTR®	3/16	4.8	Al Alloy	71220-16060	12.7	4.8	... 500
	1/4	6.4	Al Alloy	71220-16061	12.7	4.8	... 501
KLAMP-TITE®	3/16	4.8	Al Alloy	07381-04701	12.7	2.8	... 010
	1/4	6.4	Al Alloy	07612-02001	12.7	2.8	... 021

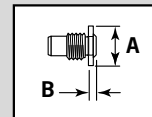
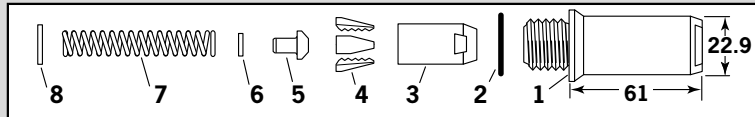

**COMPLETE TOOL
PART NUMBER :**
precede with
71233-00
or
71234-00

Nose Assemblies

Nose Tips

TYPE 2 NOSE TIPS

NOSE ASSEMBLY
part n° 71210-15200

ITEM	DESCRIPTION	PART N°
1	NOSE CASING	07340-02804
2	'O' RING	07003-00067
3	JAW HOUSING	07340-00304
4	JAWS	71210-15001
5	JAW SPREADER	07498-04502
6	BUFFER	71210-05001
7	SPRING	07500-00418
8	LOCKING RING	07340-00327
17	JAW SPREADER HOUSING	71210-02101
18	'O' RING	07003-00277

NAME	FASTENER		NOSE TIP (mm)		see below
	ϕ^1	MATERIAL	PART N°	'A' 'B'	
AVEX®	3/16	4.8 Aluminium	07340-02807	12.7 10.0	... 0 1 4
	3/16	4.8 Steel	07340-07301	12.7 11.8	... 0 1 8
BULBEX®	3/16	4.8 Aluminium	07340-02807	12.7 10.0	... 0 1 4
	-	4.3 Steel	07241-07101	12.7 10.0	... 1 2 1
T-LOK®	3/16	4.8 Steel	07241-07101	12.7 10.0	... 1 2 1
Q RIVET	3/16	4.8 Any	07340-02807	12.7 10.0	... 0 1 4

¹ In inches then in millimetres.

TYPE 2 NOSE TIPS ARE EXTENDED TO ALLOW ACCESS INTO APPLICATIONS WHERE TYPE 1 NOSE TIPS WILL NOT REACH.

COMPLETE TOOL PART NUMBER :
precede with 71233-00 or 71234-00

TYPE 5 NOSE TIP

NOSE ASSEMBLY
part n° 71230-15600

ITEM	DESCRIPTION	PART N°
1	NOSE CASING	07498-00501
2	'O' RING	07003-00067
9	CHUCK COLLET	07498-00801
4	JAWS	07220-02302
10	FRONT SPRING GUIDE	07498-00803
7	SPRING	07500-02005
11	REAR SPRING GUIDE	07498-00503
8	LOCKING RING	07340-00327
13	STOP NUT ASSY	71233-20200

NAME	FASTENER		NOSE TIP (mm)		see below
	ϕ^1	MATERIAL	PART N°	'A' 'B'	
AVTAINER®	3/8	9.6 Steel	07498-00802	19.1 4.1	... 2 4 3

¹ In inches then in millimetres.

COMPLETE TOOL PART NUMBER :
precede with 71233-00 or 71234-00

TYPE 6 NOSE TIPS

NOSE ASSEMBLY
part n° 71230-15800

ITEM	DESCRIPTION	PART N°
1	NOSE CASING	07340-00306
2	'O' RING	07003-00067
3	JAW HOUSING	07612-02003
4	JAWS	07612-02002
5	JAW SPREADER	07498-04502
6	BUFFER	07498-03003
7	SPRING	07500-00418
8	LOCKING RING	07340-00327

NAME	FASTENER		NOSE TIP (mm)		see below
	ϕ^1	MATERIAL	PART N°	'A' 'B'	
HEMLOK®	1/4	6.4 Any	07612-02001	14.3 3.6	... 2 6 1
STAVEX®	1/4	6.4 Any	07612-02001	14.3 3.6	... 2 6 1

¹ In inches then in millimetres.

COMPLETE TOOL PART NUMBER :
precede with 71233-00 or 71234-00

Nose Assemblies

Nose Tips

TYPE 7 NOSE TIPS

NOSE ASSEMBLY
 part n° 71233-15000

ITEM	DESCRIPTION	PART N°
1	NOSE CASING	07340-00306
2	'O' RING	07003-00067
3	JAW HOUSING	07612-02003
4	JAWS	71230-16101
5	JAW SPREADER	71233-15003
6	BUFFER	07498-03003
7	SPRING	07007-02130
8	LOCKING RING	07340-00327

NAME	FASTENER		MATERIAL	NOSE TIP (mm)			see below
	Ø ¹			PART N°	'A'	'B'	
AVIBULB®	1/4	6.4	Any	71233-15001	14.3	3.0	... 0 8 4
AVINOX®	1/4	6.4	Any	71233-15002	14.3	3.0	... 0 8 3

¹ In inches then in millimetres.

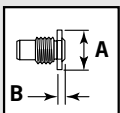

COMPLETE TOOL PART NUMBER :
 precede with
 71233-00
 or
 71234

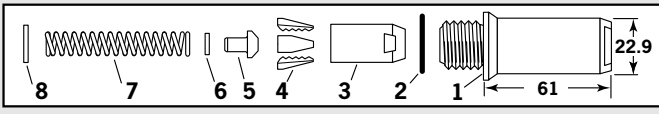

MAXLOK® - NOSE ASSEMBLY

NAME	FASTENER		MATERIAL	NOSE ASSEMBLY		see below
	Ø ¹			PART N°		
MAXLOK®	3/16	4.8	All	07610-02000	... 3 7 1	
	1/4	6.4	All	07610-02100	... 3 7 2	

¹ In inches then in millimetres.

COMPLETE TOOL PART NUMBER :
 precede with 71233-00 or 71234-00

NOSE ASSEMBLY
 part n° 07610-02000 for 3/16" Ø

ITEM	DESCRIPTION	PART N°
4	JAWS	07610-02003
7	SPRING	07610-02107
8	LOCKING RING	07610-02004
9	CHUCK COLLET	07610-02002
10	SPRING GUIDE	07220-02104
12	ANVIL	07610-02001

NOSE ASSEMBLY
 part n° 07610-02100 for 1/4" Ø

ITEM	DESCRIPTION	PART N°
4	JAWS	07610-02103
7	SPRING	07610-02107
8	LOCKING RING	07610-02004
9	CHUCK COLLET	07610-02102
10	SPRING GUIDE	07220-02104
12	ANVIL	07610-02101

ADAPTOR KIT
 part n° 71234-03400 for 3/16" Ø and 1/4" Ø

13	STOP NUT ASSY	71233-20200
14	CHUCK COLLET ADAPTOR	07610-00501
15	ANVIL ADAPTOR	71230-02063
16	ANVIL NUT	07610-00307

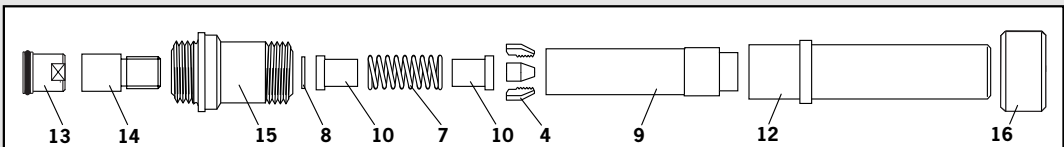

READ MAXLOK® 'FITTING INSTRUCTIONS' PAGE 14.

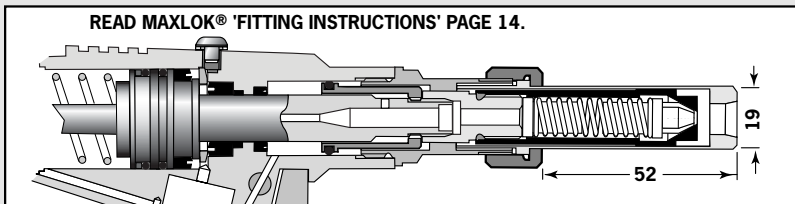

Nose Assemblies

Fitting instruction for Avtainer® and Maxlok® Nose Assemblies

IMPORTANT

The air supply must be disconnected when fitting or removing any nose assembly unless specifically instructed otherwise.

The air vacuum extraction system **MUST** be disabled by fitting Vacuum 'Shut-Off' Stop Nut 71233-20200 before operating an nG4 tool with a Maxlok® or Avtainer® nose assembly. Refer to the 'Operating Procedure' for Avtainer® and Maxlok®, page 8.

AVTAINER®

Item numbers in **bold** refer to the general assembly and parts list pages 22 and 23. Other item numbers refer to the 'Type 5 Nose Tip' table page 11.

- Remove Jaw Spreader Housing **41**, 'O' ring **12**, Locknut **40**, Vacuum Sleeve **42** and Seal Housing **52**.
- Screw Vacuum 'Shut-off' Stop Nut Assy 13 onto Head Piston **36**. (Items **40**, **42** and **52** are not refitted).
- Replace Jaw Spreader Housing **41** and 'O' Ring **12**.
- Lightly coat jaws 4 with Moly Lithium grease*.
- Drop jaws 4 into Chuck Collet 9.
- Insert Front Spring Guide 10 into Chuck Collet 9.
- Locate Spring 7 onto Front Spring Guide 10.
- Screw Rear Spring Guide 11 into Chuck Collet 9.
- Fit Locking Ring 8 onto the Jaw Spreader Housing of the tool.
- Screw the assembled Chuck Collet onto the Jaw Spreader Housing and tighten with spanner.
- Screw the Nose Tip into Nose Casing 1 and tighten with spanner*.
- Place Nose Casing 1 with 'O' Ring 2 over Chuck Collet 9 and screw onto the tool, tightening with spanner*

MAXLOK®

Item numbers in **bold** refer to the general assembly and parts list pages 22 and 23. Other item numbers refer to the 'Maxlok® Nose Assembly' table page 12.

- Remove Jaw Spreader Housing **41**, 'O' Ring **12**, Vacuum Sleeve **42**, Seal housing **52** and Locknut **40**. (None of the above parts are refitted).
- Screw Stop Nut Assy 13 onto Head Piston **36**.
- Substitute Jaw Spreader Housing **41** with Chuck Collet Adaptor 14. Tighten fully onto piston before tightening the Stop Nut Assy 13 against it.
- Fit Locking Ring 8 onto the Chuck Collet Adaptor.
- Lightly coat Jaws 4 with Moly Lithium grease.
- Drop Jaws 4 into Chuck Collet 9.
- Insert one Spring Guide 10 into Chuck Collet 9.
- Locate Spring 7 onto the Spring Guide already in place.
- Drop the other Spring Guide 10 into Spring 7.
- Holding tool pointing down, screw the assembled Chuck Collet onto the Chuck Collet Adaptor and tighten with spanner.
- Screw Anvil Adaptor 15 into the Head Assembly.
- Place Anvil 12 over Chuck Collet 9 and lock into place with Anvil Nut 16.

Service Instructions for all Nose Assemblies

Nose assemblies should be serviced at weekly intervals. You should hold some stock of all internal components of the nose assembly and nose tips as they will need regular replacement.

- Remove the nose assembly using the reverse procedure to the 'Fitting instructions'.
- Any worn or damaged part should be replaced.
- Clean and check wear on jaws.
- Ensure that the jaw spreader is not distorted.
- Check that the spring is not distorted.
- On nose assemblies for Maxlok® and Avtainer® check that the spring guides are not distorted.
- On nose assemblies for Maxlok® check that the anvil is neither cracked nor has any scoring or corrosion marks on the inside face of the concave shape at the front end.
- Assemble according to fitting instructions.

* Item included in the nG4 service kit. For complete list see page 18
Item numbers in **bold** refer to the general assembly drawing and parts list on pages 22 and 23.

Accessories

Stem Deflector

The stem deflector is a very simple alternative to the standard stem collector and allows access in restricted areas. To replace the stem collector with the stem deflector proceed as follows:

Preparing the Base Tool for use with Stem Deflector

The airline must be disconnected before any servicing or dismantling.

- Remove stem collector bottle assembly 71213-05100 or 71210-20400.

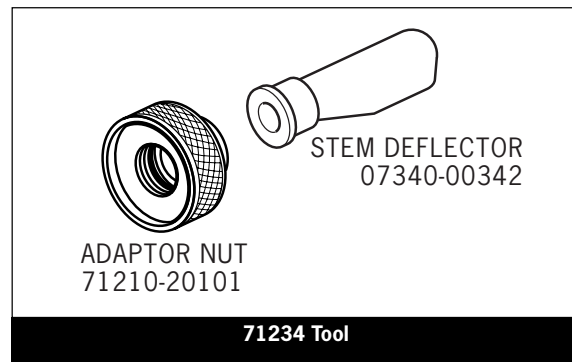
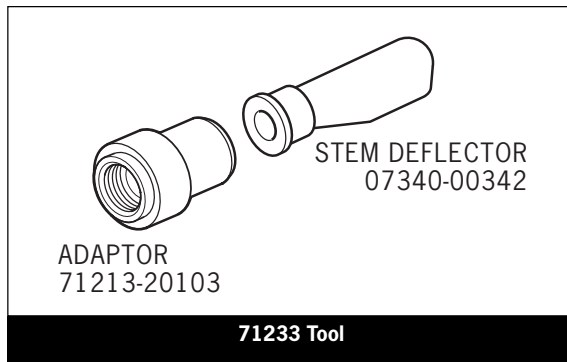
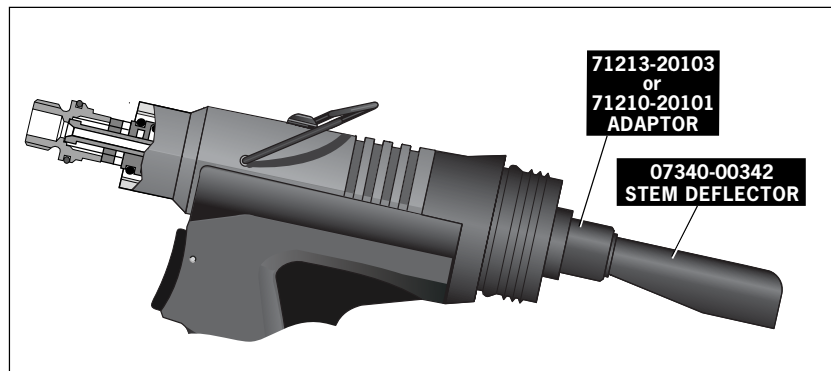

- Fit Stem Deflector (07340-00342) into Adaptor (71213-20103).
- Screw Adaptor onto End Cap Assembly 71233-05103.
- Rotate the stem deflector until the aperture faces away from the operator and any other person(s) in the vicinity.
- Fit Stem Deflector (07340-00342) into Adaptor (71210-20101).
- Screw Adaptor onto End Cap Assembly 71403-02120.
- Rotate the stem deflector until the aperture faces away from the operator and any other person(s) in the vicinity.

Extension

Fitted between the tool and the nose assembly the extension allows access into deep channels.

- To fit the extension, remove any nose assembly components.
- Screw the inner extension to Jaw Spreader Housing **41**.
- Screw the outer onto Head Assembly **58**.
- Fit the nose assembly onto the extension.

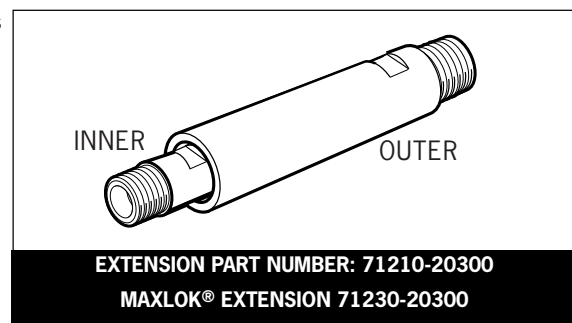

Item numbers in **bold** refer to the general assembly drawing and parts list on pages 22 and 23. **9*** refers to illustrations on page 12.

Notes

Servicing the Tool

I M P O R T A N T

Read Safety Instructions on page 4.

The employer is responsible for ensuring that tool maintenance instructions are given to the appropriate personnel.

The operator should not be involved in maintenance or repair of the tool unless properly trained.

The tool shall be examined regularly for damage and malfunction.

Daily

- Check for air leaks. If damaged, hoses and couplings should be replaced.
- If there is no filter on the pressure regulator, bleed the air line to clear it of accumulated dirt or water before connecting the air hose to the tool. If there is a filter, drain it.
- Check that the nose assembly is correct for the fastener to be placed.
- Check the stroke of the tool meets the minimum specification (page 5). The last step of the Priming Procedure on page 26 explains how to measure the stroke.
- Either a stem collector or a stem deflector must be fitted to the tool.
- Check that Base Cover **31** is fully tightened onto Body **30**.

Weekly

- Dismantle and clean the nose assembly with special attention to the jaws. Lubricate with MolyLithium grease before assembling.
- Check for oil leaks and air leaks in the air supply hose and fittings.

MolyLithium Grease EP 3753 Safety Data

Grease can be ordered as a single item, the part number is shown in the Service Kit page 18.

First Aid

SKIN:

As the grease is completely water resistant it is best removed with an approved emulsifying skin cleaner.

INGESTION:

Ensure the individual drinks 30ml Milk of Magnesia, preferably in a cup of milk.

EYES:

Irritant but not harmful. Irrigate with water and seek medical attention.

Fire

FLASH POINT: Above 220°C.

Not classified as flammable.

Suitable extinguishing media: CO₂, Halon or water spray if applied by an experienced operator.

Environment

Scrape up for incineration or disposal on approved site.

Handling

Use barrier cream or oil resistant gloves

Storage

Away from heat and oxidising agent.

Item numbers in **bold** refer to the general assembly drawing and parts list on pages 22-23.

Servicing the Tool

Molykote® 55m Grease Safety Data

First Aid

SKIN:

Flush with water. Wipe off.

INGESTION:

No first aid should be needed.

EYES:

Flush with water.

Fire

FLASH POINT: Above 101.1°C. (closed cup)

Explosive Properties: No

Suitable Extinguishing Media: Carbon Dioxide Foam, Dry Powder or fine water spray.

Water can be used to cool fire exposed containers.

Environment

Do not allow large quantities to enter drains or surface waters.

Methods for cleaning up: Scrape up and place in suitable container fitted with a lid. The spilled product produces an extremely slippery surface.

Harmful to aquatic organisms and may cause long-term adverse effects in the aquatic environment. However, due to the physical form and water - insolubility of the product the bioavailability is negligible.

Handling

General ventilation is recommended. Avoid skin and eye contact.

Storage

Do not store with oxidizing agents. Keep container closed and store away from water or moisture.

Molykote® 111 Grease Safety Data

First Aid

SKIN:

No first aid should be needed.

INGESTION:

No first aid should be needed.

EYES:

No first aid should be needed.

INHALATION:

No first aid should be needed.

Fire

FLASH POINT: Above 101.1°C. (closed cup)

Explosive Properties: No

Suitable Extinguishing Media: Carbon Dioxide Foam, Dry Powder or fine water spray.

Water can be used to cool fire exposed containers.

Environment

No adverse effects are predicted.

Handling

General ventilation is recommended. Avoid eye contact.

Storage

Do not store with oxidizing agents. Keep container closed and store away from water or moisture.

Servicing the Tool

Service Kit

For an easy complete service, Avdel offers the complete service kit below.

SERVICE KIT : 71210-99990		Spanners are specified in inches and across flats unless otherwise stated	
PART N°	DESCRIPTION	PART N°	DESCRIPTION®
07900-00667	PISTON SLEEVE	07900-00008	7/16" x 1/2" SPANNER
07900-00692	TRIGGER VALVE EXTRACTOR	07900-00012	9/16" x 5/8" SPANNER
07900-00670	BULLET	07900-00015	5/8" x 1 1/16" SPANNER
07900-00672	'T' SPANNER	07900-00686	PEG SPANNER
07900-00706	LOCATION SPIGOT	07900-00677	SEAL EXTRACTOR
07900-00684	GUIDE TUBE	07900-00698	STOP NUT
07900-00685	INSERTION ROD	07900-00700	PRIMING PUMP
07900-00351	3 MM ALLEN KEY	07992-00020	GREASE - MOLY LITHIUM E.P.3753
07900-00469	2.5 MM ALLEN KEY	07992-00075	GREASE - MOLYKOTE® 55M
07900-00158	2 MM PIN PUNCH	07900-00755	GREASE - MOLYKOTE® 111
07900-00224	4 MM ALLEN KEY	07900-00850	PIN SPANNER
07900-00734	STOP NUT - MAXLOK®	07900-00898	ROTARY VALVE HOOK
07900-00164	CIRCLIP PLIERS		

Maintenance

(Annually or every 500,000 cycles whichever is the soonest)

Annually or every 500,000 cycles the tool should be completely dismantled and new components should be used where worn, damaged or recommended. All 'O' rings and seals should be renewed and lubricated with Molykote® 55m grease for pneumatic sealing or Molykote® 111 for hydraulic sealing.

<p>IMPORTANT Read Safety Instructions on page 4. The employer is responsible for ensuring that tool maintenance instructions are given to the appropriate personnel. The operator should not be involved in maintenance or repair of the tool unless properly trained. The tool shall be examined regularly for damage and malfunction.</p>
--

The air line must be disconnected before any servicing or dismantling is attempted unless specifically instructed otherwise.

It is recommended that any dismantling operation be carried out in clean conditions.

Before proceeding with dismantling, empty the oil from the tool following the first four steps of the 'Priming Procedure' on page 26.

Prior to dismantling the tool it is necessary to remove the nose equipment. For instructions see the nose assemblies section, pages 9 to 12.

For a complete service of the tool, we advise that you proceed with dismantling of sub-assemblies in the order shown.

After any dismantling REMEMBER to prime the tool and to fit an appropriate nose assembly or swivel head.

Nose Equipment

- Unscrew Nose Casing **1** and Nose Tip.
- Unscrew Jaw Housing **3** and remove Jaws **4**, Jaw Spreader **5**, Spring **7** and Buffer **6**.
- Inspect all components. Renew all damaged or worn parts.
- Clean all parts and apply Moly Lithium Grease EP 3753 (07992-00020) to taper bore of Jaw Housing **3**.
- Insert Jaws **4**, Jaw Spreader **5**, Spring **7** and Buffer **6** into Jaw Housing **3** and assemble onto Jaw Spreader Housing **41***.
- Screw Nose Tip into Nose Casing and tighten.

Item numbers in **bold** refer to Nose Tip Tables on pages 10 to 12.

41* refers to illustration on page 22.

Servicing the Tool

Dismantling the Tool

Before dismantling the tool the oil must be emptied from it.

- With the air supply switched OFF at ON/OFF Valve Assembly **62** remove Bleed Screw **1** and Bonded Seal **6**.
- Insert tool over a suitable container, switch air supply ON and actuate tool.
- Oil will expel from bleed screw orifice into container.
- Switch air supply OFF after all oil is expelled.

Ensure the bleed screw orifice is facing away from the person performing this operation.

Item numbers in **bold** refer to the General Assembly and Parts List of Common parts on pages 22 and 23.

Head Assembly

71233 Tool with Removable Stem Collector Bottle

- Quarter turn and pull off stem Collector Bottle Assembly **9**. See illustration on page 8.
- Unscrew Retaining Nut **8** together with Deflector **7**.
- Pull off Bottle Adaptor **6**.
- Unscrew End Cap Assembly **4** together with 'O' Rings **2, 3** and Lip Seal **1**.

or

71234 Tool with Fixed Stem Collector Bottle

- Rotate the Stem Collector Outer so that the aperture in the stem Collector Body is fully exposed.
- Unscrew the Retaining Nut **3**.
- Remove the Fixed Collector Bottle Assembly **4**.
- Remove the Bottle Adaptor Assembly **8**.
- Unscrew and remove the End Cap Assembly **2** together with Lip Seal **1**, 'O' Ring **7** and Seal **6**.

Item numbers in **bold** above refer to the Stem Collector Bottles Removable and Fixed on page 24.

then

- Remove Spring **91**.
- Loosen Locknut **40** with a spanner* and unscrew Jaw Spreader Housing **41** together with 'O' Ring **12**.
- Withdraw Vacuum Sleeve **42**.
- Remove Locknut **40** together with 'O' Rings **19** and **15**.
- Push Head Piston **36** to the rear and out of Head Assembly **58** taking care not to damage the cylinder bore.
- Remove Seal Retainer **43**. Push Lip Seal **8** and Bearing Tape **26** to the rear and out of Head Assembly **58** taking care not to damage the cylinder bore.
- Remove Seal Housing **52** and Lip Seal **2**.

Assemble in reverse order noting the following points:

- Place Lip Seal **8** onto the insertion rod* ensuring correct orientation. Locate the guide tube* into the head of the tool and push the insertion rod* with the seal in place through the guide tube*. Pull the insertion rod* out and then the guide tube*.
- The chamfered edge of Seal Retainer **43** must face forward with the gap at the bottom.
- After fitting Lip Seal **11**, 'O' Ring **18** (x2) and Bearing Tape **27** onto the Head Piston **36** ensuring correct orientation, lubricate the cylinder bore and place the piston sleeve* into the back of Head Assembly **58**. Slide the bullet* onto the threaded part of Head Piston **36** and push the piston with the seals through the piston sleeve* as far as it will go. Slide the bullet* off the piston and remove piston sleeve*.
- Jaw Spreader Housing **41** must be fully tightened onto Head Piston **36** before tightening Locknut **40** against it.
- Reprime in accordance with the instructions on page 26.

* Item included in the nG4 Service Kit. For complete list see page 18.

Item numbers in **bold** refer to the General Assembly and Parts List of Common parts on pages 22 and 23.

Servicing the Tool

Pneumatic Piston Assembly

- Remove 'ON/OFF' Valve Assembly **62**.
- Clamp the body of the inverted tool **ACROSS THE AIR INLET BOSSES** in a vice fitted with soft jaws.
- Pull off Rubber Boot **48**.
- Using the peg spanner* unscrew Base Cover **31**.
- Unscrew Nyloc Nuts **67** (2 off) and remove Base Plate Assembly **65**.
- Remove Cylinder Liner **37** together with Sealing Washers **29** (2 off) and 'O' Rings **66** (2 off).
- Remove Pneumatic Piston Assembly **57** together with 'O' Ring **75**, Lip Seal **90** (3 off) and Guide Ring **51**.
- Engage the Seal Extractor* into Seal Assembly **60** and withdraw Seal Assembly from intensifier tube of the Head Assembly **58**.

Assemble in reverse order to dismantling.

- Seals should be checked for damage and replaced as necessary. Lubricate pneumatic seals with Molykote® 55m and hydraulic seals with Molykote® 111.

Air Valve

Dismantling

- Remove Pneumatic Piston Assembly **57** as described above in Pneumatic Piston Assembly.
- Using Spanner (07900-00672), and Location Spigot Assembly (07900-00706). Unscrew Clamp Nut **39** and remove together with Top Plate Assy **44** together with Tie Rods **56**, Transfer Tube Assembly **61**, 'O' Rings **14** and Silencer **53**.
- Remove tool from vice and separate Body **30** from Handle **64**. Remove 'O' Ring **17**.
- Push out the Valve Seat **34**, from the Body **30**, together with 'O' Rings **14**.
- Pull out Valve Spool Assembly **59** from Handle Assembly **64**. Remove 'O' Ring **7** from handle counterbore.

Assembly

Assemble in reverse order to Dismantling Instructions

- Seals should be checked for damage and replaced if necessary, lubricated with Molykote® 55m grease.
- Apply Loctite® 243 to Clamp Nut **39** and tighten to torque 11ftlb (14.91 Nm).

IMPORTANT

Check the tool against daily and weekly servicing.
Priming is **ALWAYS** necessary after the tool has been dismantled and prior to operating.

* Item included in the nG4 Service Kit. For complete list see page 18.
Item numbers in **bold** refer to the general assembly drawing and parts list on pages 22 and 23.

Servicing the Tool

Rotary Valve

Dismantling

- Remove Pneumatic Piston Assembly **57** as described in Pneumatic Piston Assembly.
- Using Spanner (07900-00672), and Location Spigot Assembly (07900-00706), unscrew Clamp Nut **39** and remove together with Top Plate Assembly **44** together with Tie Rods **56**, Transfer Tube Assembly **61**, separate Body **30** from Handle Assembly **64**. Remove 'O' Rings **16** and **17**.
- Separate Head Assembly **58** from Handle Assembly **64**.
- Push out Rotary Valve **38** together with 'O' Rings **5**.

Assemble in reverse order to Dismantling Instructions noting the following:

- Seals should be checked for damage and replaced if necessary, lubricated with Molykote® 55m grease.

Trigger

Dismantling

- Using a 2mm pin punch (07900-00158) drive Trigger Pin **46** out and remove Trigger **33**.
- Unscrew Trigger Valve **21** using trigger valve extractor (07900-00692).

Assemble in reverse order to Dismantling Instructions.

Item numbers in **bold** refer to the general assembly drawing and parts list on pages 22 and 23.

Common parts

Parts List for Common Parts 71233-02000 and 71234-02000

71233-02000 and 71234-0200 PARTS LIST				* These are minimum recommended levels of spares based on regular servicing			
ITEM	PART N°	DESCRIPTION	QTY SPARES	ITEM	PART N°	DESCRIPTION	QTY SPARES
01	71230-02041	BLEED SCREW	1	48	71221-02007	RUBBER BOOT	1
02	07003-00333	LIP SEAL	1	49	71233-02027	LABEL	1
04	07003-00127	'O' RING	1	51	71230-03205	GUIDE RING	1
05	07003-00189	'O' RING	2	52	71210-02104	SEAL HOUSING	1
06	07003-00194	M5 BONDED SEAL	1	53	71210-02031	SILENCER	2
07	07003-00271	'O' RING	1	56	71221-02004	TIE ROD	2
08	07003-00273	LIP SEAL	1	57	71231-03210	PNEUMATIC PISTON ASSEMBLY (ITEMS 51, 75 & 90)	1
11	07003-00341	LIP SEAL	1	58	71233-03330	HEAD ASSEMBLY	1
12	07003-00277	'O' RING	1	59	71210-03400	VALVE SPOOL ASSEMBLY (ITEMS 96, 98, 99 & 109)	1
14	07003-00281	'O' RING	3	60	71230-03800	SEAL ASSEMBLY	1
15	07003-00204	'O' RING	1	61	71230-03600	TRANSFER TUBE ASSEMBLY	1
16	07003-00287	'O' RING	1	62	71210-03700	ON/OFF VALVE ASSEMBLY	1
17	07003-00288	'O' RING	2	64	71213-02016	HANDLE ASSEMBLY	1
18	07003-00342	'O' RING	2	65	71221-02014	BASE PLATE ASSEMBLY	1
19	07003-00310	'O' RING	1	66	07003-00027	'O' RING	2
21	07005-00088	TRIGGER VALVE	1	67	07002-00108	M6 NYLOC NUT	2
22	07005-01274	1/8" BSP PLUG	1	71	71221-20105	MODIFIED COUNTER	1
23	07008-00010	6" FLEXIBLE HOSE	1	72	71221-20101	COUNTER MouldING	1
24	07007-00224	3mm DIAx1.0mm SPIROL PIN	2	73	71221-20103	MOULDING RETAINING NUT	2
26	71233-02021	BEARING TAPE - PISTON ROD	1	74	71221-20102	SPECIAL M4 SCREW	2
27	71213-02022	BEARING TAPE - PISTON	1	75	07003-00182	'O' RING	1
29	71221-02006	SEALING WASHER	2	76	07002-00163	WASHER	2
30	71223-02001	BODY MACHINED	1	77	07007-01993	CENTRE POLE MAGNET	1
31	71221-02002	BASE COVER	1	79	71221-20104	M5 X 19 COUNTERSUNK SCREW	1
33	71213-02051	TRIGGER	1	80	07002-00098	M5 NYLOC NUT	1
34	71210-02009	VALVE SEAT	1	90	07003-00274	LIP SEAL	3
36	71233-02121	HEAD PISTON	1	91	07490-03002	SPRING	1
37	71221-02008	CYLINDER LINER	1	96	07003-00268	'O' RING	1
38	71210-02013	ROTARY VALVE	1	97	07003-00398	'O' RING	2
39	71210-02014	CLAMP NUT	1	98	07003-00042	'O' RING	1
40	71210-02103	LOCKNUT	1	99	71210-03401	VALVE BODY	1
41	71210-02101	JAW SPREADER HOUSING	1	100	07007-01503	LABEL BOOK SYMBOL	1
42	71230-02102	VACUUM SLEEVE	1	103	07900-00841	TOOL INSTRUCTION MANUAL (NOT SHOWN)	1
43	71230-02019	SEAL RETAINER	1	105	07900-00849	NOSE EQUIPMENT SPANNER (NOT SHOWN)	1
44	71213-02010	TOP PLATE ASSEMBLY	1	106	07900-00890	SEAL KIT DATA SHEET (NOT SHOWN)	1
45	71210-02022	SUSPENSION RING	1	108	71213-03001	WARNING LABEL	1
46	71210-02024	TRIGGER PIN	1	109	71210-03402	VALVE SPOOL	1

Stem Collector Bottles Removable and Fixed

71233 Tool Removable

REMOVABLE STEM COLLECTOR BOTTLE		
ITEM	DESCRIPTION	PART NUMBER
1	LIP SEAL	07003-00374
2	O-RING	07003-00278
3	O-RING	07003-00398
4	END CAP ASSEMBLY	71233-05103
5	WARNING LABEL	71213-03001
6	BOTTLE ADAPTOR	71213-05104
7	DEFLECTOR	71213-05101
8	RETAINING NUT	71213-05102
9	COLLECTOR BOTTLE ASSEMBLY	71213-05100

71234 Tool Fixed

FIXED STEM COLLECTOR BOTTLE		
ITEM	DESCRIPTION	PART NUMBER
1	LIP SEAL	07003-00374
2	END CAP ASSEMBLY	71231-02001
3	RETAINING NUT	71210-02028
4	FIXED COLLECTOR BOTTLE ASSEMBLY	71210-20400
6	SEAL	71210-02029
7	O' RING	07003-00278
8	BOTTLE ADAPTOR ASSEMBLY	71403-02110

Priming

Priming is ALWAYS necessary after the tool has been dismantled and prior to operating. It may also be necessary to restore the full stroke after considerable use, when the stroke may have been reduced and fasteners are not now being fully placed by one operation of the trigger.

Oil Details

The recommended oil for priming is Hyspin® VG32 available in 0.5 litre (part number 07992-00002) or one gallon containers (part number 07992-00006). Please see safety data below.

Hyspin® VG32 Oil Safety Data

First Aid

SKIN:

Wash thoroughly with soap and water as soon as possible. Casual contact requires no immediate attention. Short term contact requires no immediate attention.

INGESTION:

Seek medical attention immediately. DO NOT induce vomiting.

EYES:

Irrigate immediately with water for several minutes. Although NOT a primary irritant, minor irritation may occur following contact.

Fire

Flash point 232°C. Not classified as flammable.

Suitable extinguishing media: CO₂, dry powder, foam or water fog. DO NOT use water jets.

Environment

WASTE DISPOSAL: Through authorised contractor to a licensed site. May be incinerated. Used product may be sent for reclamation.

SPILLAGE: Prevent entry into drains, sewers and water courses. Soak up with absorbent material.

Handling

Wear eye protection, impervious gloves (e.g. of PVC) and a plastic apron. Use in well ventilated area.

Storage

No special precautions.

Priming Kit

To enable you to follow the priming procedure opposite, you will need to obtain a priming kit:

PRIMING KIT : 07900-00688	
PART N°	DESCRIPTION
07900-00351	3mm ALLEN KEY
07900-00700	PRIMING PUMP
07900-00224	4mm ALLEN KEY

Priming

Priming Procedure

I M P O R T A N T

**DISCONNECT THE TOOL FROM THE AIR SUPPLY OR SWITCH OFF AT ON/OFF VALVE ASSEMBLY 62.
REMOVE NOSE ASSEMBLY .**

**All operations should be carried out on a clean bench, with clean hands in a clean area.
Ensure that the new oil is perfectly clean and free from air bubbles.**

Care MUST be taken at all times, to ensure that no foreign matter enters the tool, or serious damage may result.

- Switch OFF air supply at ON/OFF Valve Assembly **62**.
- Remove all nose equipment. (see page 9).
- Remove Bleed Screw **1** and Bonded Seal **6**.
- Invert tool over suitable container, switch ON air supply at ON/OFF Valve Assembly **62** and actuate tool.
- Residual oil in the tools hydraulic system will empty through bleed screw orifice.

CARE SHALL BE TAKEN TO ENSURE THAT THE BLEED HOLE IS NOT DIRECTED TOWARDS THE OPERATOR OR OTHER PERSONNEL.

- Switch air supply OFF at ON/OFF Valve Assembly **62**.
- Screw priming pump (07900-00700) into bleed screw port, utilising Bonded Seal **6**.
- Actuate Priming Pump by pressing down and releasing several times until resistance is evident and the Head Piston starts to move rearward.

ENSURE PUMP IS KEPT 'SQUARE' TO BLEED SCREW PORT DURING PRIMING OPERATION TO PREVENT BREAKAGE OF BLEED NIPPLE ON PRIMING PUMP.

- Remove the priming pump, surplus oil will expel from bleed screw port.
- Replace the Bleed Screw **1** together with Bonded Seal **6**.
- Switch ON air supply at ON/OFF Valve Assembly **62**.
- Check that the stroke of the head piston reaches specification. If not repeat above procedure.
- Switch OFF air supply and refit nose equipment. (see page 9).
- Check that the stroke of the tool meets the minimum specification of 14 millimetres. To check the stroke, measure the distance between the front face of the jaw spreader housing and the front of the head, BEFORE pressing the trigger and when the trigger is fully actuated. The stroke is the difference between the two measurements. If it does not meet the minimum specification, repeat the Priming Procedure.

Item numbers in **bold** refer to the general assembly drawing and parts list on pages 22 and 23.

Fault Diagnosis

Symptom	Possible Cause	Remedy	Page Ref
More than one operation of the trigger needed to place fastener	Air leak	Tighten joints or replace components	
	Insufficient air pressure	Adjust air pressure to within specification	5
	Worn or broken jaws	Fit new jaws	9
	Low oil level or air in oil	Prime tool	25, 26
	Build up of dirt inside the nose assembly	Service nose assembly	9
Tool will not grip stem of fastener	Worn or broken jaws	Fit new jaws	9, 10, 11, 12
	Build up of dirt inside the nose assembly	Service nose assembly	9
	Loose jaw housing	Tighten against locking ring	9
	Weak or broken spring in nose assembly	Fit new spring	9, 10, 11, 12
	Incorrect component in nose assembly	Identify and replace	10, 11, 12
Jaws will not release broken stem of fastener	Build up of dirt inside the nose assembly	Service nose assembly	9
	Jaw housing, nose tip or nose casing not properly seated	Tighten nose assembly	10, 11, 12
	Weak or broken spring in nose assembly	Fit new spring	10, 11, 12
	Air or oil leak	Tighten joints or replace components	
	Low oil level or air present in oil	Prime tool	25, 26
Cannot feed next fastener	Broken stems jammed inside tool	Empty stem collector	8
		Check jaw spreader is correct	10, 11, 12
		Adjust air pressure to within specification	5
Slow cycle	Low air pressure	Adjust air pressure to within specification	5
	Build up of dirt inside the nose assembly	Service nose assembly	9
Tool fails to operate	No air pressure	Connect and adjust to within specification	5
	Damaged Trigger Valve 21	Replace	21
Fastener fails to break	Insufficient air pressure	Adjust air pressure to within specification	5
	Fastener outside tool capability	Use more powerful Genesis tool. Contact Avdel UK Limited	
	Low oil level or air present in oil	Prime tool	25, 26

Item numbers in **bold** refer to the general assembly drawing and parts list on pages 22 and 23.
Other symptoms or failures should be reported to your local Avdel® authorised distributor or repair centre.

Declaration of Conformity

We, Avdel UK Limited, Watchmead Industrial Estate, Welwyn Garden City, Herts, AL7 1LY
declare under our sole responsibility that the product:

Model nG4

Serial No.

to which this declaration relates is in conformity with the following standards:

EN ISO 12100 - parts 1 & 2	
BS EN ISO 8662 - part 6	BS EN ISO 11202
BS EN ISO 3744	BS EN 982
ISO EN 792 part 13 - 2000	BS EN 983

following the provisions of the Machine Directive 2006/42/EC.

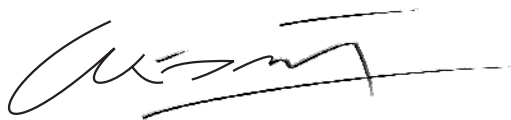

A. Seewraj - Product Engineering Manager - Automation Tools

Date of issue



**This box contains a power tool which is in
conformity with Machines Directive
2006/42/EC. The 'Declaration of Conformity'
is contained within.**

Notes

Holding your world together®

Find your closest STANLEY Engineered Fastening location on www.StanleyEngineeredFastening.com/contact



For an authorized distributor nearby please check www.StanleyEngineeredFastening.com/econtact/distributors

Manual Number	Issue	C/N
07900-00931	C3	14/076

STANLEY
Engineered Fastening

www.StanleyEngineeredFastening.com

© 2013 Stanley Black & Decker, Inc., Rev. 01.2014

Avbolt®, Avdel®, Avdelok®, Avex®, Avinox®, Avseal®, Avtainer®, Hemlok®, Maxlok® and Monobolt® are trademarks of Avdel UK Limited. The names and logos of other companies mentioned herein may be trademarks of their respective owners. Data shown is subject to change without prior notice as a result of continuous product development and improvement policy. Your local Avdel representative is at your disposal should you need to confirm latest information.

Avdel UK Limited
Pacific House, 2 Swiftfields
Welwyn Garden City, Hertfordshire AL7 1LY
Tel. +44 (0)1707 292-000 AFax -199
enquiries2@sbdinc.com