

POP[®]

INSTRUCTION MANUAL

ProSet[®] 2500 Series

Pneumatic Blind Rivet Tool



EMHART[®]
TEKNOLOGIES

Contents

Introduction.....	2
Safety Instructions.....	3
Specifications	4
Packaged Accessories.....	4
Tool Requirements.....	4
ProSet® 2500 Tool Dimensions.....	5
Common Nosepieces.....	6
Basic Tool Operation	6
Front End Service.....	7
Mandrel Collection System (MCS) – ProSet® 2500 MCS	8
Cleaning the Collector Silencer.....	8
Tool Assembly Torque Requirements.....	9
ProSet® 2500/2500MCS Diagram	10
Parts List	12
Hydraulic Oil Charging Procedure.....	14
Maintenance.....	15
Safety Data.....	16
Troubleshooting.....	17
EC Declaration of Conformity	18

Introduction

POP® ProSet® 2500 tools are light weight Air/Hydraulic rivet setting tools recommended for use with genuine POP Brand Rivets per following chart:

Rivet Type	Material (Body – Mandrel)	Rivet Diameter		
		1/8"(*) [3.2 mm]	5/32"(*) [4.0 mm]	3/16"(**) [4.8 mm]
Open End & MultiGrip	Al – Al	✓	✓	✓
	Al – St / SS	✓	✓	✓
	St – St	✓	✓	✓
	SS – SS; Mo – St /SS	✓	✓	✓(†)
Closed End	Al – Al	✓	✓	✓
	Al – St / SS; Cu – St	✓	✓	✓
	St – St	✓	✓	✓
	SS – SS	✓	✓	✓
LSR Rivets	Al – Al	✓	✓	✓
HR™ Rivets	St – St	✓	✓(**)	✓
T - Rivet	Al – St	✓	✓	✓
Self Plugger	St – St	✓	✓	✓
UltraGrip	Al-Al , St- St, SS-SS	-	-	✓

Al: Aluminum, St: Steel, SS: Stainless Steel, Cu: Cooper, Mo: Monel

(*) Use FAN275-028 Jaw pusher set up.

(**) Use DPN275-027 Jaw pusher set up.

(†) Exclude MultiGrip™



Safety Instructions



TO INSURE PROPER FUNCTIONING AND SAFE OPERATION READ THIS MANUAL CAREFULLY BEFORE SETTING UP OR OPERATING THE POP® ProSet™ 2500 SERIES TOOLS

1. **DO NOT** use this tool in a manner other than that recommended by Emhart Teknologies.
2. Always wear eye protection when using or when near a tool that is in use.
3. This tool is **NOT** designed for use in explosive atmospheres.
4. Inspect tool for damage before connecting to air supply including all air connections.
5. Trained personnel must perform tool repair and/or maintenance at the prescribed intervals.
6. Disconnect the air supply when adjusting, servicing or removing any part of the tool.
7. Keep fingers off the trigger when connecting the air supply or if the air supply fails.
8. Keep fingers away from the front of the tool when connecting the air supply or setting rivets.
9. **DO NOT** point the tool at anyone.
10. **DO NOT** operate tool with the nose housing removed.
11. **DO NOT** operate tool without the Deflector or Collector.
12. **DO NOT** modify the tool in any way. Modification will make void any applicable warranties and could result in damage to the tool or physical injury to the user.
13. **DO NOT** look into the tool from the front or the back during use or when connected to air supply.
14. The operating pressure must not exceed 100 psi (6.9 bar).
15. **DO NOT** direct tool exhaust towards anyone.
16. Wash hands if exposed to hydraulic fluid or lubricant.
17. Keep hair, fingers and loose clothing away from moving parts of the tool.

Specifications

	ProSet® 2500	ProSet® 2500MCS
Weight	2.65 lbs. (1.20 kg)	2.89 lbs. (1.31 kg)
Length	11.42" (290 mm)	11.97" (304 mm)
Height	10.20" (259 mm)	10.20" (259 mm)
Tool stroke	0.71" (18 mm)	0.71" (18 mm)
Pulling force	2110 lbs @ 90 PSI (9400 N @ 6.2 bar)	2110 lbs @ 90 PSI (9400 N @ 6.2 bar)
Air consumption	0.076 cu. ft. per rivet (2.15 liters per rivet)	2.47 scfm (MAX) (70 l/min (MAX))

Packaged Accessories

Qty	Item	PROSET 2500	PROSET 2500MCS	Part No.
1	ProSet® 2500 Rivet Tool	✓	✓	-
1	Operating Instructions	✓	✓	P449
1	Maintenance Manual	✓	✓	P534
1	Nosepiece for 4 size open end rivets	✓	✓	PRN414
1	Nosepiece for 5 size open end rivets	✓	✓	PRN514
1	Nosepiece for 6 size open end rivets	Installed	Installed	PRN614
1	Jaw Pusher (Assy.) for 1/8,5/32" rivets	✓	✓	FAN275-028
1	Air Line Assembly	✓	✓	FAN239-157
1	4 mm Hex. Socket Screw Key	✓	✓	DPN239-139
1	Warranty Card	✓	✓	FG2184

Tool Requirements

Air supply *	6 scfm (150 l/min) Minimum
Recommended Operating Pressure	72.5-90 PSI (5.0-6.2 Bar) dry, filtered
Maximum Operating Pressure	100 PSI (6.9 Bar) dry, filtered
Hydraulic Oil **	POP® p/n: PRG540-130 [1 qt. (.945 ml)]
Jaw Lubricant **	POP® p/n: PRG510-130 [6 oz. (177 ml)]
Seal Lubricant **	POP® p/n: PSA075508P [1 ¾ oz. (54 g)]

(*) Note: For best results and long service life, use dry, filtered air supply.

(**) Note: See lubricant safety information.

ProSet® 2500 Tool Dimensions

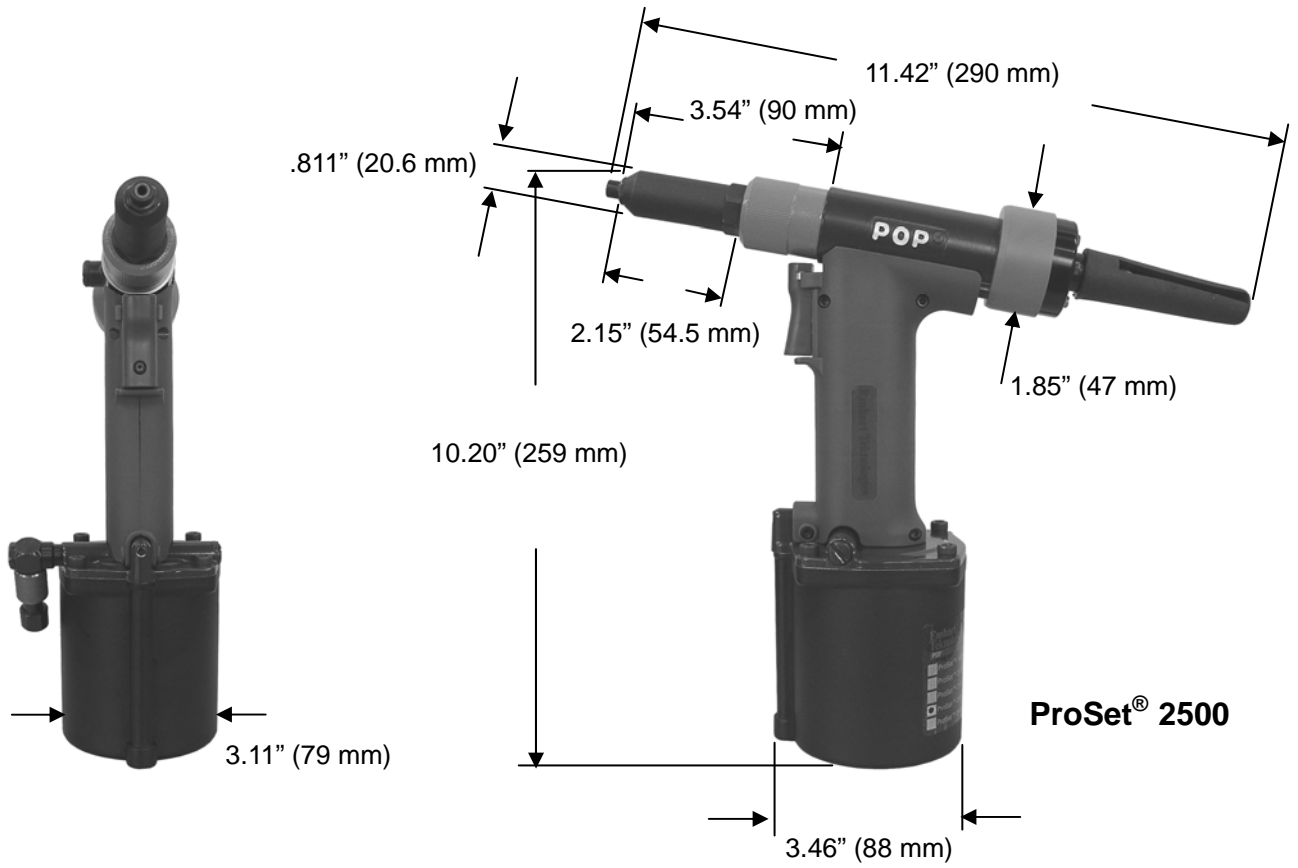

ProSet® 2500

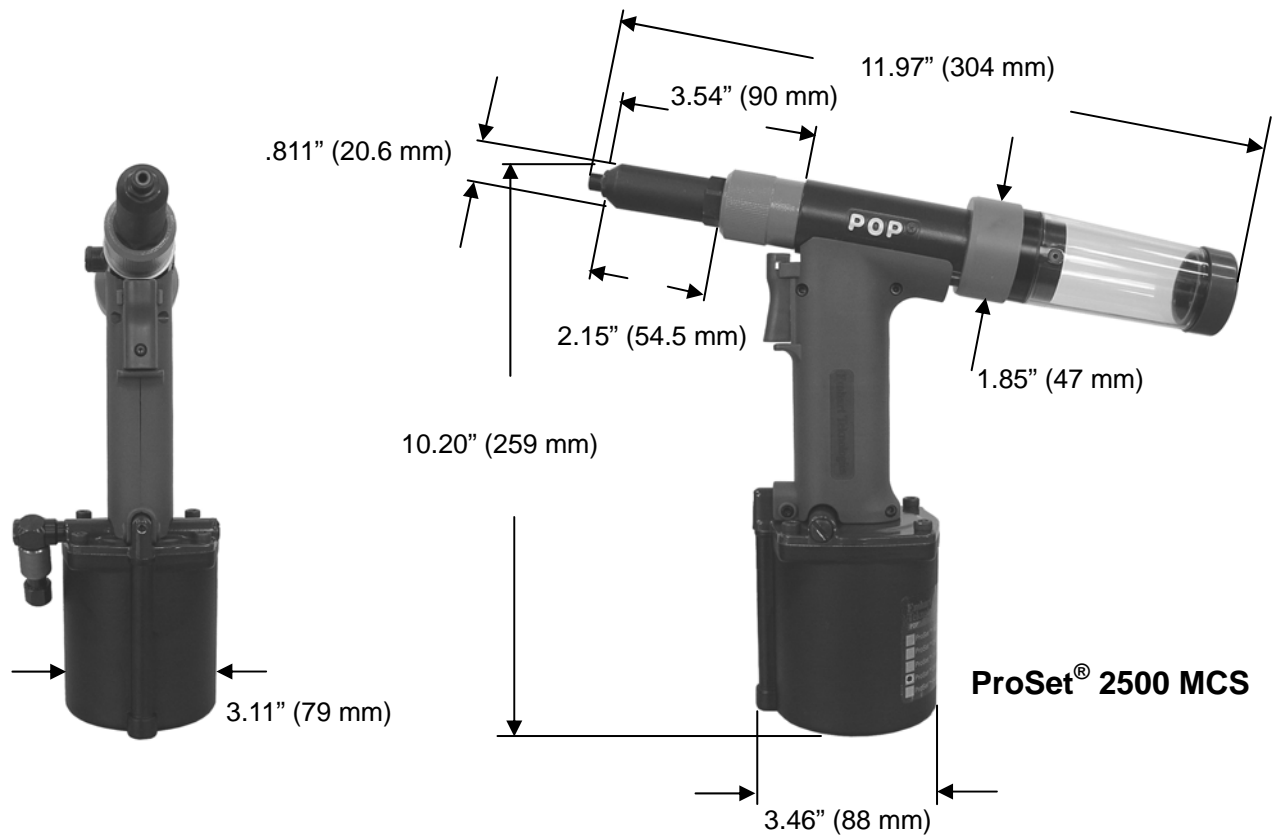

ProSet® 2500 MCS

Common Nosepieces

Rivet Diameter	Open End	Closed End		HR Rivets		Jaw Pusher
		Steel Mandrel	Aluminum Mandrel	Aluminum Body	Steel Body	
1/8" (3.2 mm) or 7/64" (2.8 mm)	PRN414*	PRN424	PRN434	PRN414*	PRN4K	FAN275-028*
5/32" (4.0 mm)	PRN514*	PRN524	PRN534	PRN514*	-	
	-	-	-	-	PRN5K	DPN275-027*
3/16" (4.8 mm)	PRN614*	PRN624	PRN634	PRN614*	PRN6K	

* Included with the tool

Use FAN275-028 instead of DPN275-027 (installed) when using 7/64" (2.8mm) - 5/32" (4.0mm).
Use N-406 nosepiece when using 3/16" (4.8mm) UltraGrip® rivets; use N-410 for Monobolt® rivets.

Basic Tool Operation

Before operating the tool check the following:

- Inspect tool for damage or leaking oil – **do not use tool if it is damaged or leaking oil.**
- Check that correct nosepiece is fitted and tightened to 60 - 65 in-lbs [6.8 – 7.3 N-m] torque.
- Check that the nose housing nut (8) is tight – hand tighten only.
- Connect tool to air supply – see air supply requirements (page 4).
- Fit Mandrel Collector (96) – (MCS tool only).
- Open air supply valve by Sliding red OS Sleeve (93) on side of tool (see note below).
- Insert rivet into nosepiece.
- Position rivet in work piece.
- Pull trigger to set rivet.
- Release trigger – if equipped, MCS suction will draw mandrel into the collector.

! Note: The ProSet™ 2500 has an OS (Open-Shut) Valve for switching the air supply ON and OFF to save air when the tool is not in use.

Air Supply ON: Open OS Valve by sliding OS Slider in the direction shown (up).

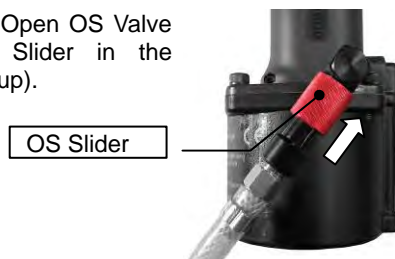

Air Supply OFF: Close OS Valve by sliding OS Slider in the direction shown (down).



ProSet® 2500 Front End Service

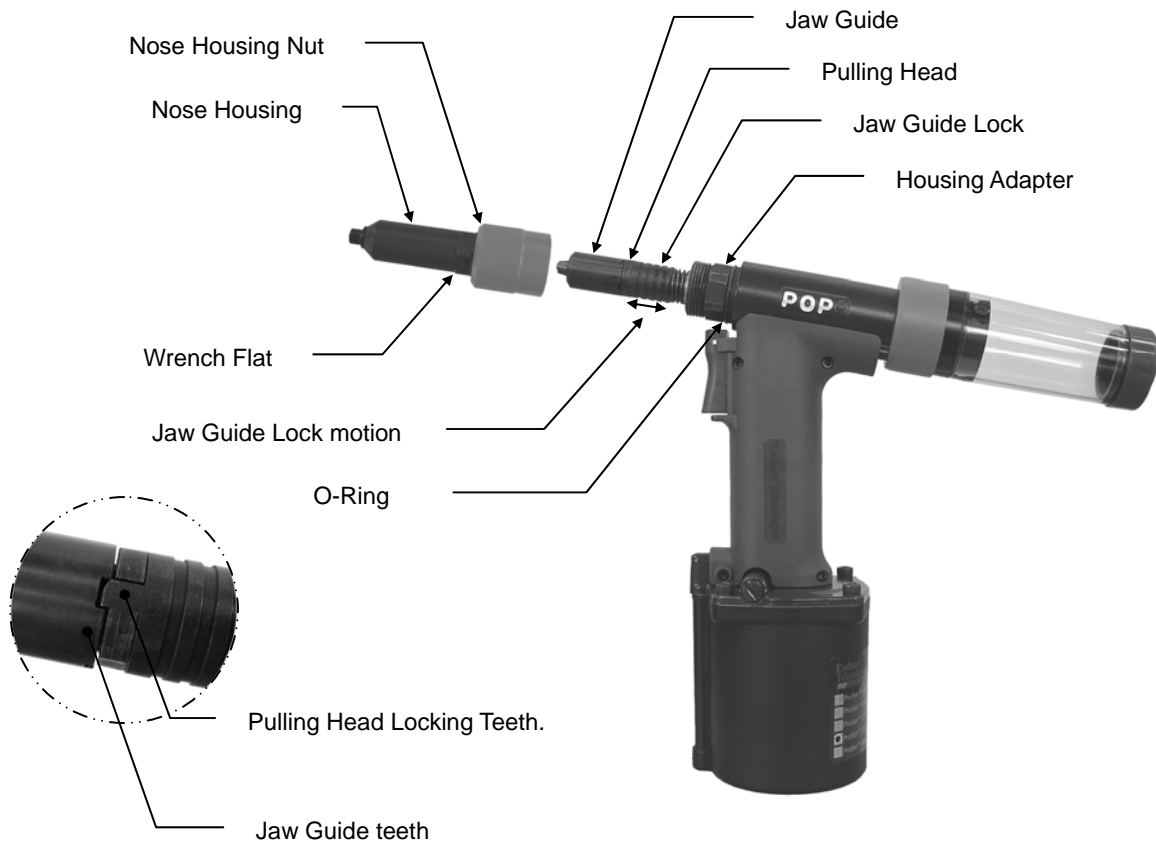

For optimum tool performance, Front-End maintenance should be performed regularly as per the “Preventative Maintenance Schedule”.

! Note: UNPLUG AIR SUPPLY while servicing front-end to avoid INJURY.

1. REMOVE NOSE HOUSING:

Unscrew the Nose Housing Nut by hand and slide Nose Housing off the tool.

2. REMOVE JAW GUIDE TO ACCESS JAWS AND INTERNAL PARTS:

Pull back the Jaw Guide Lock to disengage the Jaw Guide Lock teeth and unscrew and remove the Jaw Guide.

Remove Jaws, Jaw Pusher, and Jaw Pusher Spring for servicing.

3. CLEAN PARTS:

Clean Jaws, Jaw Guide, Jaw Pusher, Spring and thread area of the Pulling Head. Apply Seal Lube to outside surface of Jaws and inside surface of the Jaw Guide.

4. REASSEMBLY OF INTERNAL PARTS AND JAW GUIDE:

Place the Jaws into the Jaw Guide and slide the Jaw Pusher Spring and Jaw Pusher into the Pulling Head.

Apply a small amount of Seal Lube to the Pulling Head threads and Jaw Guide Lock teeth. Screw the Jaw Guide onto the Pulling Head until the teeth on the Jaw Guide Lock stop the Jaw Guide rotating.

Apply Jaw lubricant to the Jaw area by submerging the assembled Jaw Guide into Jaw lube about 1 in. (25mm). Clean off excess Jaw Lube from the outside of the Jaw Guide.

5. REINSTALL NOSE HOUSING ASSEMBLY:

Refit the Nose Housing and Hand-tighten the Nose Housing Nut securely against the O-Ring. If the Nut is not tightened sufficiently against the O-Ring there may be a loss of suction.

Mandrel Collection System (MCS) – ProSet® 2500 MCS

For safety purposes, removing the Collector from the tool automatically turns the MCS suction OFF. Refitting the Collector turns the MCS suction ON.



MCS suction ON

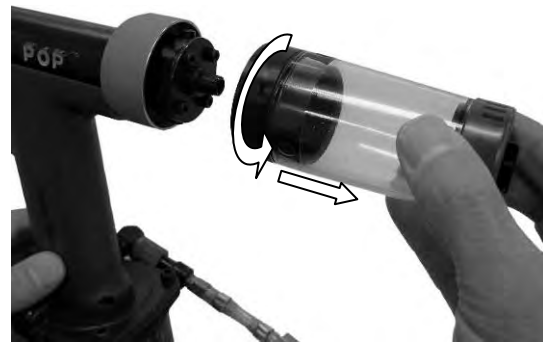

MCS suction OFF

Cleaning the Collector Silencer

For optimum performance, the Collector Silencer should be cleaned at regular intervals as per the "Preventative Maintenance Schedule".

! Note: UNPLUG AIR SUPPLY while servicing Collector to avoid INJURY.

1. CLEAN THE COLLECTOR :

Remove and empty the Collector (96) by turning counterclockwise.
Remove the Collector End Nut (106) (17mm wrench) and remove the Collector End Cap (105).
Remove the Collector Silencer (103).
Clean and remove debris from all components.

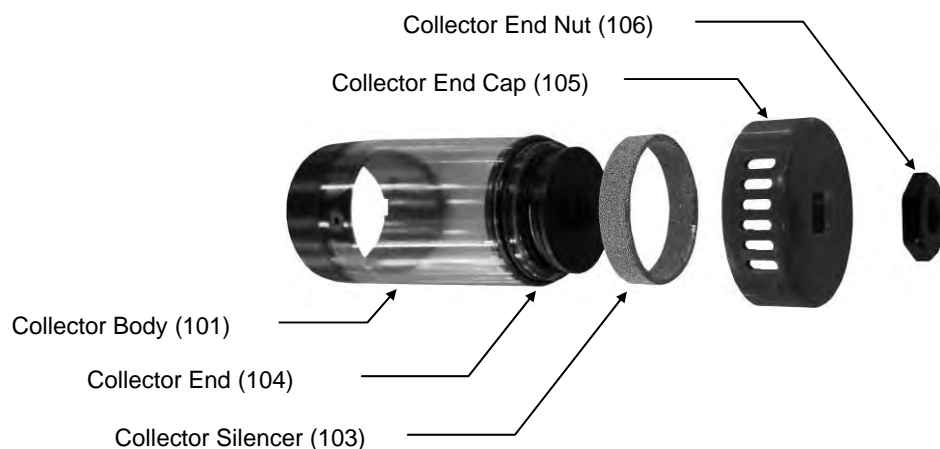

2. RE-ASSEMBLE THE COLLECTOR :

Secure Collector End (104) to Collector Body (101). Use a screwdriver or similar tool to hold the Collector End in place during re-assembly (see picture below).
 Place the Collector Silencer (103) onto the Collector End (104).
 Place Collector End Cap (105) on Collector Body End (104).
 Install and tighten Collector End Nut (106) on Collector End (104).

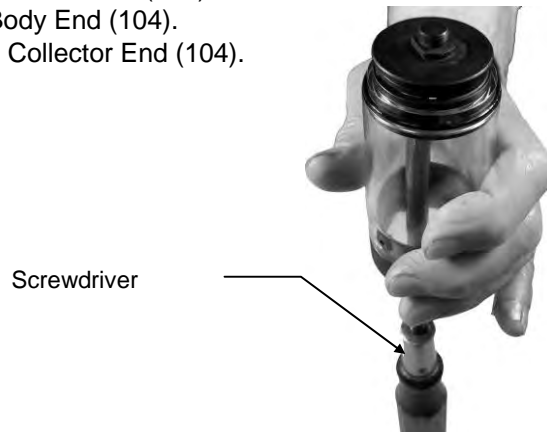

Tool Assembly Torque Requirements

Item	Part No.	Description	Torque Value
1	PRN614	Nosepiece 6 size	
119	PRN414	Nosepiece 4 size	60 – 65 in-lbs (6.8 – 7.3 N-m)
120	PRN514	Nosepiece 5 size	
51	DPN239-053	Sleeve Lower	35 - 39 ft-lbs (47 - 53 N-m)
61	DPN239-063	Sleeve Lock Nut	31 - 35 ft-lbs (42 - 48 N-m)
88	DPN907-003	Socket Head Cap Screw	46 - 51 in-lbs (5.2 – 5.8 N-m)

See exploded Tool Diagram

ProSet[®] 2500/2500MCS Diagram

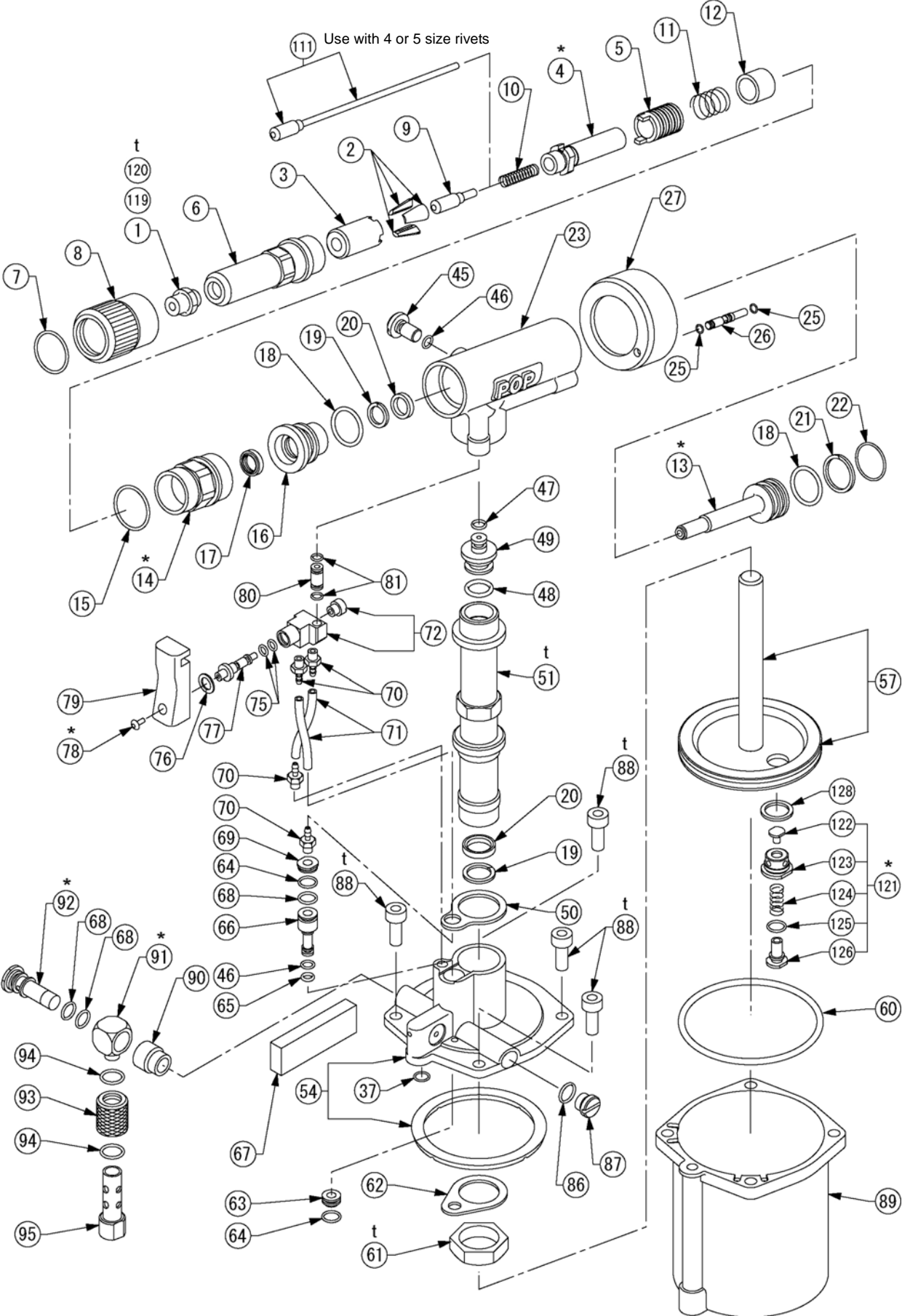

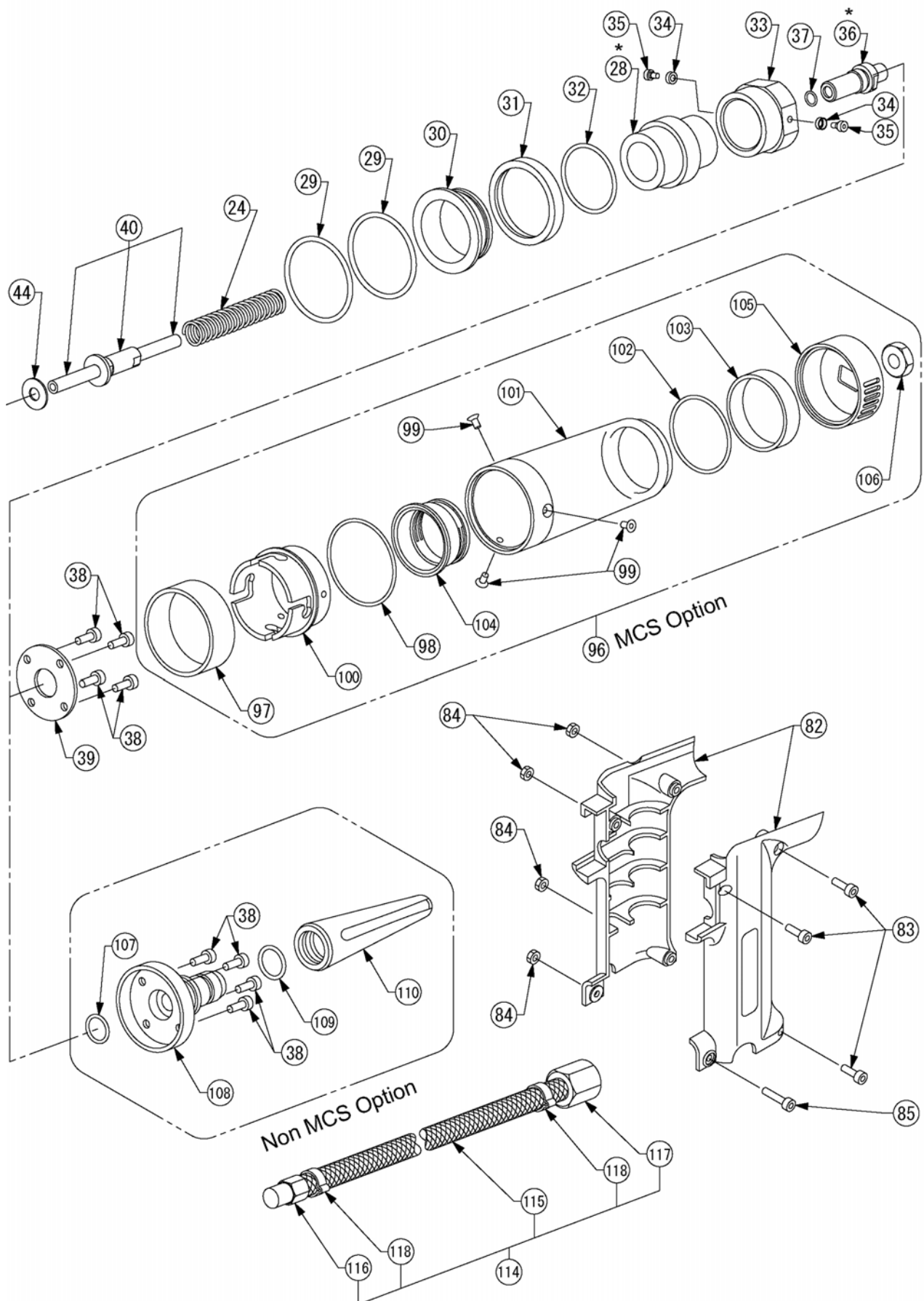

(*) These items require Loctite® 242 adhesive.

(†) These items have a specific tightening torque as indicated in the "Tool Assembly Torque Requirements" table.

ProSet[®] 2500 Parts List

Item	Part No.	Description	2500	2500 MCS	Item	Part No.	Description	2500	2500 MCS
1	PRN614	Nose Piece	1	1	76	DPN902-001	Retaining Ring	1	1
2	13300	13300	1set(3)	1set(3)	77	DPN239-078	S Valve Rod	1	1
3	DPN275-001	Jaw Guide	1	1	78	DPN906-001	Button Head Cap Screw	1	1
4	DPN275-002	Pulling Head	1	1	79	DPN239-150	Trigger	1	1
5	DPN275-003	Jaw Guide Lock	1	1	80	DPN239-083	Connect Tube	1	1
6	DPN275-004	Nose Housing	1	1	81	DPN900-015	O-Ring	2	2
7	DPN900-027	O-Ring	1	1	82	DPN239-151	Handle Assembly	1	1
8	DPN275-005	Nose Housing Nut	1	1	83	DPN907-001	Socket Head Cap Screw	3	3
9	DPN275-027	Jaw Pusher	1	1	84	DPN239-086	Hexagon Nut	4	4
10	DPN901-005	Jaw Pusher Spring	1	1	85	DPN907-004	Socket Head Cap Screw	1	1
11	DPN901-006	Spring	1	1	86	DPN900-016	O-Ring	1	1
12	DPN275-006	Spring Receiver	1	1	87	DPN239-089	Plug	1	1
13	DPN275-007	Hydraulic Piston	1	1	88	DPN907-003	Socket Head Cap Screw	4	4
14	DPN275-008	Housing Adapter	1	1	89	DPN275-021	Chamber	1	1
15	DPN900-024	O-Ring	1	1	90	DPN239-126	R Joint Spacer	1	1
16	DPN275-009	Rod Seal Case	1	1	91	DPN239-093	R Joint	1	1
17	DPN908-007	Scraper	1	1	92	DPN239-127	R Joint Adapter	1	1
18	DPN900-029	O-Ring	2	2	93	DPN239-095	O S Slider	1	1
19	DPN908-006	B.U-Ring	2	2	94	DPN900-017	O-Ring	2	2
20	DPN908-005	Penta Seal	2	2	95	DPN239-097	O S Joint	1	1
21	DPN908-008	B.U-Ring	1	1	96	FAN275-035	Collector (Assembly)	-	1
22	DPN900-028	O-Ring	1	1	97	DPN239-098	Collector Lock Collar	-	1
23	DPN275-010	Handle Upper	1	1	98	DPN900-018	O-Ring	-	1
24	DPN901-007	Return Spring	1	1	99	DPN903-001	Flat Head Cap Screw	-	3
25	DPN900-005	O-Ring	2	2	100	DPN239-155	Collector Lock	-	1
26	DPN239-111	MCS Valve Rod	1	1	101	DPN275-036	Collector Body	-	1
27	DPN275-031	MCS Cap	1	1	102	DPN900-020	O-Ring	-	1
28	DPN275-032	End Cap Adapter	1	1	103	DPN239-168	Collector Silencer	-	1
29	DPN900-019	O-Ring	2	2	104	DPN239-156	Collector End	-	1
30	DPN275-033	Slider	1	1	105	DPN239-167	Collector End Cap	-	1
31	DPN275-037	Slider Pusher	1	1	106	DPN239-152	Collector End Nut	-	1
32	DPN900-026	O-Ring	1	1	107	DPN900-021	O-Ring	1	-
33	DPN239-153	End Cap	1	1	108	DPN239-163	Deflector Adapter	1	-
34	DPN239-116	Collar	2	2	109	DPN900-022	O-Ring	1	-
35	DPN239-154	Collar Screw	2	2	110	PRG510-56	Deflector	1	-
36	DPN275-034	Ejector Guide	1	1	111	FAN275-028	Jaw Pusher Assembly	1	1
37	DPN900-006	O-Ring	2	2	114	FAN239-157	Air Line Assembly	1	1
38	DPN907-002	Socket Head Cap Screw	4	4	115	DPN239-158	Air Line	1	1
39	DPN239-119	End Cap Plate	-	1	116	DPN239-159	Air Line Fitting	1	1
40	FAN275-011	Ejector (Assembly)	1	1	117	DPN239-160	Hose Female Fitting	1	1
44	DPN239-108	Packing	1	1	118	PRG540-45	O-Clamp (0911)	2	2
45	DPN239-047	Fill Screw	1	1	119	PRN414	Nose Piece 4Size	1	1
46	DPN900-007	O-Ring	2	2	120	PRN514	Nose Piece 5Size	1	1
47	DPN900-008	O-Ring	1	1	121	FAN275-022	EXT Valve Assembly	1	1
48	DPN900-009	O-Ring	1	1	122	DPN275-025	EXT Valve Head	1	1
49	DPN275-014	Sleeve Upper	1	1	123	DPN275-024	EXT Valve Case	1	1
50	DPN239-052	Upper Plate	1	1	124	DPN901-008	EXT Valve Spring	1	1
51	DPN239-053	Sleeve Lower	1	1	125	DPN900-030	O-Ring	1	1
54	FAN275-015	Handle Lower Assembly	1	1	126	DPN275-023	EXT Valve Rod	1	1
57	FAN275-018	Air Piston Assembly	1	1	128	DPN275-026	Washer	1	1
60	DPN900-025	O-Ring	1	1	NS	DPN239-139	HS Screw key - M4	1	1
61	DPN239-063	Sleeve Lock Nut	1	1					
62	DPN239-064	Bottom Plate	1	1					
63	DPN239-065	J Valve Cap	1	1					
64	DPN900-011	O-Ring	2	2					
65	DPN900-012	O-Ring	1	1					
66	DPN239-068	J Valve Rod	1	1					
67	DPN239-069	EXT Silencer	1	1					
68	DPN900-013	O-Ring	3	3					
69	DPN239-071	Valve Stopper	1	1					
70	DPN239-120	Fitting	4	4					
71	DPN239-121	Air Tube	2	2					
72	FAN239-074	S.V Case Assembly	1	1					
75	DPN900-014	O-Ring	2	2					

Optional Parts and Kits are also available separately.

Part No.	Description
DPN239-110	17mm Hex. Socket screw key for End Cap Adapter (DPN275-032)
FAN275-132	ProSet™ 2500 Font End Extension Kit – 5.5" [140mm] length Contains:
5	DPN275-003 Jaw Guide Lock 1
7	DPN900-027 O-Ring 1
8	DPN275-005 Nose Housing Nut 1
11	DPN901-006 Spring 1
	DPN275-127 Nose Housing 1
	DPN275-128 Pulling Head Extension 1
	DPN275-129 Pulling Head Joint 1
	FAN275-130 Jaw Pusher (Assembly) 1
FAN275-133	ProSet® 2500/2500MCS Seal kit Contains:
7	DPN900-027 O-Ring 1
15	DPN900-024 O-Ring 1
17	DPN908-007 Scraper 1
18	DPN900-029 O-Ring 2
19	DPN908-006 B.U-Ring 2
20	DPN908-005 Penta Seal 2
21	DPN908-008 B.U-Ring 1
22	DPN900-028 O-Ring 1
37	DPN900-006 O-Ring 2
46	DPN900-007 O-Ring 1
60	DPN900-025 O-Ring 1
68	DPN900-013 O-Ring 2
94	DPN900-017 O-Ring 2
FA203-408	ProSet® 2500 Adaptor Kit for MCS5000 (remote MCS) Contains:
	MCS5000-78 Adapter Cap 1
	MCS5000-81 Strain Relief 1
	PRT5250-24 Tapered Bushing 4 size rivets 1
	PRT5250-26 Tapered Bushing 5 & 6 size rivets 1
	PRT5250-98 Fitting for 5 & 6 size rivets 1
	PRT5250-99 Fitting for 4 size rivets 1
FAN275-134	ProSet® 2500 MCS Retrofit Kit Contains:
39	DPN239-119 End Cap Plate 1
96	FAN275-035 Collector Assembly 1

Hydraulic Oil Charging Procedure

! IMPORTANT. TOOL MUST BE DISCONNECTED FROM THE AIR SUPPLY. USE ONLY APPROVED HYDRAULIC OIL SPECIFIED IN THIS MANUAL.

1. Disconnect from air supply.
2. Remove Nose Housing (6) and Collector (96).
3. Remove four Socket Head Cap Screws (88) using 4mm Hex-Key wrench (accessory). (Fig. 1)
4. Turn tool upside down and remove Chamber (89). Then pull out Air Piston Assembly (57). (Fig. 2)
5. Drain the oil from the tool into a waste oil container.
6. Clean the dirt off the Air Piston Assembly (57) and inner Chamber (89) with a clean rag. Apply a thin layer of Seal Lube to inner Chamber.
7. Loosen Jaw Guide (3) approximately 3 full turns or a 0.12" (3mm) gap and loosen Fill Screw (45) approximately 3 - 3½ full turns or a 0.14" (3.6mm) gap (Fig. 3).
8. Secure the tool upside down again and pour hydraulic oil into Sleeve Lower (51) to the level of the Backup Ring (white part) (19). (Fig. 4)
9. Push Air Piston Assembly (57) into Sleeve Lower (51) to half-way point so that dirty hydraulic oil and air bubbles will come out from the loosened Fill Screw (45). Hold Air Piston Assembly until no more oil or bubbles come out. (Fig. 5)
10. Loosely tighten Fill Screw (45) and pull out Air Piston Assembly (57).
11. Pour more hydraulic oil into Sleeve Lower (51) to the level of the Backup Ring and push Air Piston Assembly (57) into Sleeve Lower (51). Push Air Piston inwards then outwards 5-6 times in a slow, constant motion. Then pull it out and check for bubbles rising to the oil surface. If there are still bubbles, repeat the procedure until there are no more bubbles (Fig. 6).
It may be necessary to repeat this procedure 2-3 times to bleed all bubbles from the oil.
If after 3 attempts there are still bubbles in the oil, go back to No.5 and start again by draining the hydraulic oil.

Fig. 1

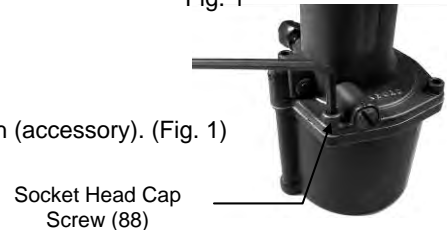

Fig. 2



Fig. 3

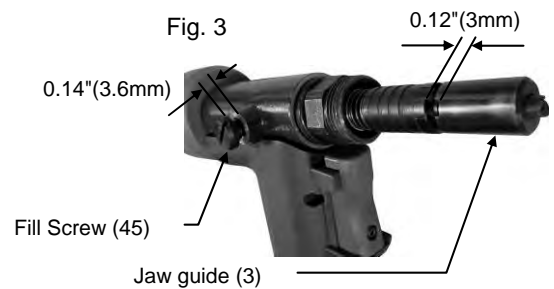

Fig. 4



Fig. 5

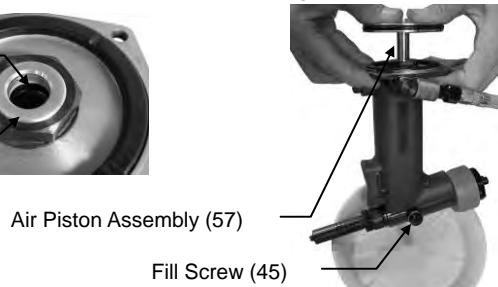
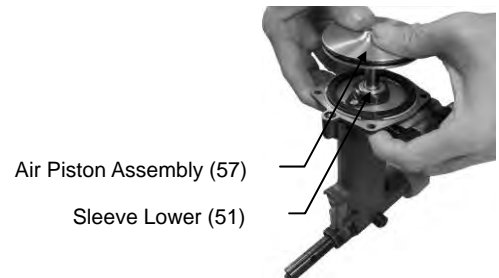

Fig. 6



12. When there are no more bubbles in the oil, top off the hydraulic oil in the Sleeve Lower (51) to the level of the Backup Ring (19).
13. Make sure the Jaw Guide (3) is loose (see No.7). Push the Air Piston Assembly (57) into the Sleeve Lower (51) to the half-way point. While holding the Air Piston at the half-way point, replace the Nose Housing and hand tighten.
14. With a clean rag, wipe off any oil on the Air Piston Assembly (57), Handle Lower Assembly (54), and Sleeve Lower (51). Put Chamber (89) over Air Piston Assembly (57) then turn the tool upright and tighten the four Socket Head Cap Screws (88) to a Torque of 46 - 51 in-lbs (5.2 – 5.8 N-m).
15. Remove the Nose Housing (6), and tighten the Jaw Guide (3) by hand until it stops.
16. Loosen the Fill Screw (45) approximately 3 - 3½ full turns or a 0.14"(3.6mm) gap to allow excess hydraulic oil and bubbles to escape. When no more oil comes out, tighten the Fill Screw (Fig. 7).
17. Wipe off any dirt and oil on the tool.
18. Replace the Nose Housing (6) and Collector (96).

Fig. 7



Note: During assembly and disassembly, do not allow any metal swarf or dirt into the Hydraulic Oil and inner Chamber.

Maintenance

Preventative Maintenance Schedule		
Item	Action	Frequency
Clean and lubricate Front End of tool	See "Front End Service"	1 x per day or 5,000 rivet settings.
Inspect jaws	Look for broken jaws and damage or wear on jaw teeth.	During "Front End Service" or when jaws slip on mandrel.
Collector	Empty Collector	When the quantity of stored spent Mandrels starts to interfere with mandrels entering the Collector. (Storage quantity depends on rivet – approx. 50-70 3/16" (4.8mm) rivets).
	Clean Collector Silencer	Once a week or when MCS suction will not pull spent mandrels into the Collector.

Note: Only use Emhart specified greases and lubricants

Safety Data

SEAL LUBE (P/N: PSA075508P)

LUBRIPLATE® 130-AA

Manufactured by:
Fiske Brothers Refining Co.
Phone: (419) 691-2491
Emergency: (800) 255-3924

ALVANIA® EP Grease 1

Prod Code: 71124
Manufactured by:
Shell Oil Products
Phone: (877) 276-7285
MSDS#: 57072E-5

First Aid:

SKIN:
Remove any contaminated clothing and wash with soap and warm water. If injected by high pressure under skin, regardless of the appearance of its size, contact a physician IMMEDIATELY. Delay may cause loss of affected part of body.

INGESTION:

Call a physician immediately. Do not induce vomiting.

EYES:

Flush with clear water for 15 minutes or until irritation subsides. If irritation persists, consult a physician.

Fire:

FLASH POINT: COC- 400°F
Cool exposed containers with water. Use foam, dry chemical, carbon dioxide or water spray.

Environment:

WASTE DISPOSAL:
Assure conformity with applicable disposal regulations. Dispose of absorbed material at an approved waste disposal facility or site.

SPILLAGE:

Scrape up grease, wash remainder with suitable petroleum solvent or add absorbent.

Handling/ Storage:

Keep containers closed when not in use. Do not handle or store near heat, sparks, flame or strong oxidants.

Lubriplate® is a registered trademark of Fiske Brothers Refining Company.

JAW LUBE (P/N: PRG510-130)

SUNPAR 107

Manufactured By:
Sunoco, Inc.
Emergency Phone: (800) 424-9300

First Aid:

SKIN:
Wash with soap and water until no odor remains. If redness or swelling develops, obtain medical assistance. Wash cloths before reuse.

INGESTION:

Do not induce vomiting! Do not give liquids! Obtain emergency medical attention. Small amounts that accidentally enter mouth should be rinsed out until taste of it is gone.

EYES:

Flush with water.

Fire:

FLASH POINT: Greater than 200°F
Can be made to burn. Use water spray, regular foam, dry chemical or carbon dioxide.

Environment:

WASTE DISPOSAL:
Do not flush to drain or storm sewer. Contract authorized disposal service.

SPILLAGE:

Contain Spill. Absorb onto inert material. Shovel, sweep or vacuum spill.

Handling/ Storage:

NFPA Class IIIB Storage. Avoid prolonged breathing of mist or vapor. Avoid prolonged or repeated contact with skin. Avoid contact with eyes. Wash thoroughly after handling.

HYDRAULIC OIL (P/N: PRG540-130)

MOBIL DTE 26

Manufactured By:
ExxonMobil Corporation
Emergency Phone: (609) 737-4411
MSDS Fax on Demand:
(613) 228-1467 MSDS # 602649-00

Shell TELLUS 68

Manufactured By:
SOPUS Products
Health Information: (877) 504-9351
MSDS Assistance:
(877) 276-7285 MSDS # 402288L-0

Distributed By:

Emhart Teknologies
Phone: (203) 924-9341

First Aid:

SKIN:
Remove contaminated clothing and shoes and wipe excess from skin. Flush skin with water, then wash with soap and water. If irritation occurs, get medical attention.

INGESTION:

Do not induce vomiting. In general, no treatment is necessary unless large quantities of product are ingested. However, get medical attention.

EYES:

Flush with water. If irritation occurs, get medical attention.

Fire:

FLASH POINT: 390°F/198.9°C
Material will float and can be re-ignited on the surface of water. Use water fog, 'alcohol foam', dry chemical or carbon dioxide (CO₂) to extinguish flames. Do not use a direct stream of water.

Environment:

SPILLAGE:
Soak up residue with an absorbent such as clay, sand or other suitable material. Place in a non-leaking container and seal tightly for proper disposal.

Handling:

Wash with soap and water before eating, drinking, smoking, applying cosmetics or using toilet. Properly dispose of leather articles such as shoes or belts that cannot be decontaminated. Use in a well ventilated area.

Storage:

Store in a cool, dry place with adequate ventilation. Keep away from open flames and high temperatures.

Please refer to the actual MSDS for complete safety and handling information. These can be obtained from the point of purchase.

Troubleshooting

Symptom	Probable Cause	Remedy
TOOL FAILS TO OPERATE	Tool not connected to air supply. OS Valve is in "OFF" position. Insufficient air pressure. Air pressure is too high. Tool is low on hydraulic fluid.	Connect to recommended air supply source. Slide OS Valve to ON position. Adjust air supply pressure. Adjust air supply pressure. Service tool by qualified service personnel.
TOOL NOT RETURNING	Possible jam due to debris in Nose Housing.	Perform "Front End Service" and check for debris or damage.
TOOL LOSING STROKE	Tool low on hydraulic fluid.	Service tool by qualified service personnel.
JAWS SLIPPING ON MANDRELS	Jaws dirty or need lubrication. Jaws worn.	Clean and lube jaws. Replace jaws.
JAWS FAIL TO OPEN	Dirty Nose Housing, Jaws or Jaw Guide. Nose Housing loose. Excess hydraulic oil in tool.	Perform "Front End Service" and clean inside of Nose Housing. Tighten Nose Housing. Service tool by qualified service personnel.
MANDREL STICKING IN JAWS	Jaws dirty or need lubrication.	Perform "Front End Service" to clean and lubricate Jaws.
RIVET FAILS TO INSERT INTO NOSEPIECE	Incorrect nosepiece. Shear ring stuck in hole of nosepiece.	Install correct nosepiece. Remove shear ring, check for the correct Nosepiece and review application parameters to ensure proper riveting.
RIVET MANDREL DOES NOT BREAK	Rivet not fully set. Mandrel break load requirement too high. Insufficient air pressure.	Repeat stroke required, or change rivet. Upgrade tool. Adjust air supply pressure to recommended level.
MCS NOT WORKING	Tool not connected to air supply. Collector not tight or missing. Mandrel path blocked.	Connect to recommended air supply source. Check Collector. Clear mandrel path.
LOW VACUUM	Dirty Silencer. Collector is full of mandrels. Insufficient air pressure.	Clean or change Silencer. Discard the mandrels. Adjust air supply pressure.

EC Declaration of Conformity

We, Emhart Teknologies

Tucker Fasteners Limited
Birmingham B42 1BP
United Kingdom.

Declare that:

ProSet[®] 2500 / 2501
ProSet[®] 2500 / 2501 MCS

Conforms to the following standards:

EN 292 part 1 and part 2
ISO 3744
ISO prEN 792 part 1
EN ISO 4871

ISO prEN 15744
EN 28662 - 1
EN 12096

Following the provisions of the Machine Directive 98/37/EEC which replaces Directive 89/392/EEC and its amending Directives 91/368/EEC, 93/44/EEC and 93/68/EEC.



Signed: _____
Eymard Chitty, Vice President, R&D

Birmingham

1st, July 2007

Notes

POP[®]

Blind Rivets

Emhart Teknologies

USA Office

50 Shelton Technology Center
Shelton, CT 06484
Tel: 877-EMHART-1
FAX: 800-225-5614

Canada Office

9870 Boulevard du Golf
Anjou, Quebec Canada
Tel: 514-351-0330
FAX: 514-351-0458

Mexico Office

Av. Antonio Dovali Jaime No 70
Torre B Piso 9
La Fe, Santa Fe
Mexico, D.F. 01210
Tel: 52-55-5326-7100
FAX: 52-55-5236-7141

www.emhartamericas.com

© Emhart Teknologies

P534.r1 (01/12)

EMHART[®]
TEKNOLOGIES

A StanleyBlack&Decker, Inc. Company